

A Practical Guide to 'Free Energy' Devices

Devices Part 3: Last updated: 1st November 2007

Author: Patrick J. Kelly

2. Energy can be captured via a strong and very brief magnetic pulse (continued)

Ed Gray snr/Creative Science, Robert Adams, John Bedini, Paul Baumann

Note: The information in this document is presented solely for study and research purposes and must not be interpreted as an encouragement to actually construct or use any of the devices described in it. Should you decide to do so in spite of this statement, then all of the responsibility for your actions remains with you and you alone, neither the author, web site owner, web hoster, or any of the people mentioned in this document are in any way at all liable for any accident, damage or injury which might occur through your actions.

Meyer/Bedini/Tesla/Boyce/Gray

One very interesting feature of free-energy devices is that although various devices which appear to be completely different and have different apparent applications, the background operation is often the same. It is clear that a sharp positive going DC electric pulse interacts with the surrounding energy field, making large quantities of free-energy available for anyone who has the knowledge of how to gather and use that extra energy.

Let me stress again that "over-unity" is an impossibility. Over-unity suggests that more energy can be taken out of a system than the total energy which goes into the system. This is not possible as you can't have more than 100% of anything. However, there is another perfectly valid way of looking at the operation of any system, and that is to rate the output of the system relative to the amount of energy that the user has to put in to make it work. This is called the "Coefficient Of Performance" or "COP" for short. A COP = 1 is when all of the energy put in by the user is returned as useful output. A COP > 1 is where more useful energy comes out of the device than the user has to put in. For example, a sailing boat in a good breeze transports people along without the need for the energy of movement to be supplied by the crew. The energy comes from the local environment and while the efficiency is low, the COP is greater than 1. What we are looking for here is not something to tap wind energy, wave energy, sunlight energy, river energy, thermal energy or whatever but instead we want something which can tap the invisible energy field which surrounds us all, namely the "zero-point energy" field.

For this, let us look at pulsing circuits from Stan Meyer, John Bedini, Nikola Tesla, Bob Boyce and Stephen Mark. Stan Meyer is aimed at making hydroxy gas, John Bedini at charging batteries, Nikola Tesla at ever-charged batteries while powering an electrical load, Bob Boyce at toroidal energy pick-up for electrolysis, and Stephen Mark at powering an electrical load with just a special coil device. Fairly different objectives, but circuitry which operates in a remarkably similar way.

Firstly, an electrical "pulse" is a sudden voltage rise and fall with very sharply rising and falling voltages. However, pulses are seldom generated as isolated events when working with practical devices, so it is probably better to think of a train of pulses, or a "waveform" with very sharp rising and falling edges. These can be called oscillators or signal generators and are so commonplace that we tend not to give them a second thought, but the really important factors for using an oscillator for zero-point energy pick-up is the quality of the signal. Ideally, what is needed is a perfect square wave with no overshoot, and the voltage level never going below zero volts. This is a good deal more difficult to achieve than you would imagine.

One such suitable circuit is shown as part of Dave **Lawton's** replication of Stan Meyer's Water Fuel Cell as described in the detailed D14.pdf document which forms part of this set of documents. Here, an ordinary NE555 timer chip generates a square wave which feeds a carefully chosen Field-Effect Transistor the BUZ350 which drives the cell via a combined pair of choke coils at point "A" in this diagram:

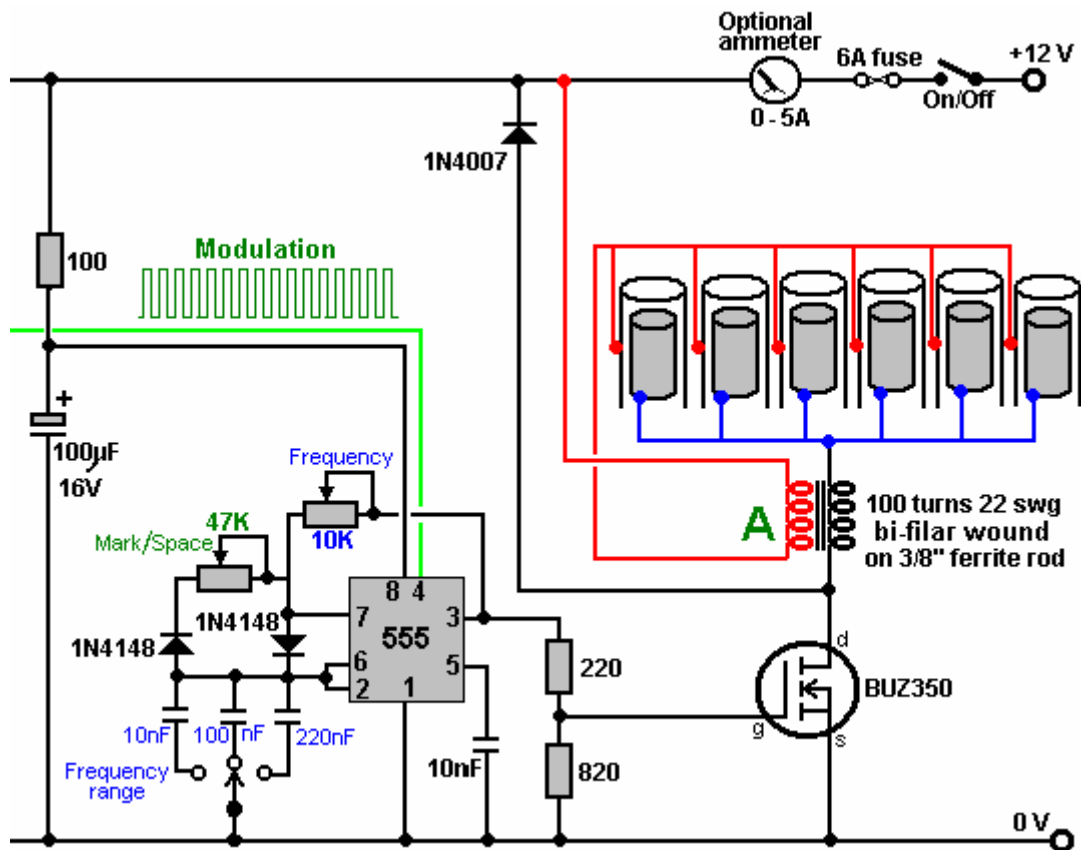

Stan Meyer used a toroidal ferrite ring when he was winding these choke coils while Dave Lawton uses two straight ferrite bars, bridged top and bottom with thick iron strips. The effects are the same in both cases, with the waveform applied to the pipe electrodes being converted into very sharp, very short, high-voltage spikes. These spikes interface with the environment and draw additional power into the circuit. The cell runs cold, and at low input current, quite unlike an ordinary electrolysis cell where the temperature rises noticeably and the input current needed is much higher.

John **Bedini** has designed a whole series of pulse-generator circuits, all based on the 1:1 multi-strand choke coil component disclosed in his patent US 6,545,444 as shown here:

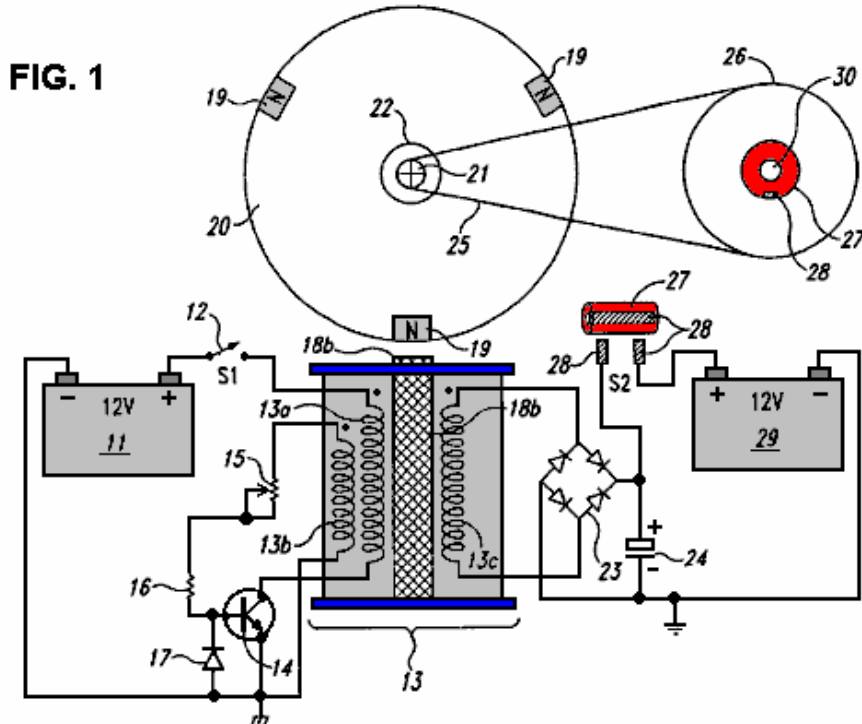

All of these pulse designs are basically the same. This one uses a free-running rotor with permanent magnets embedded in it's rim, to trigger sharp induced currents in the windings of the coil unit marked "13".

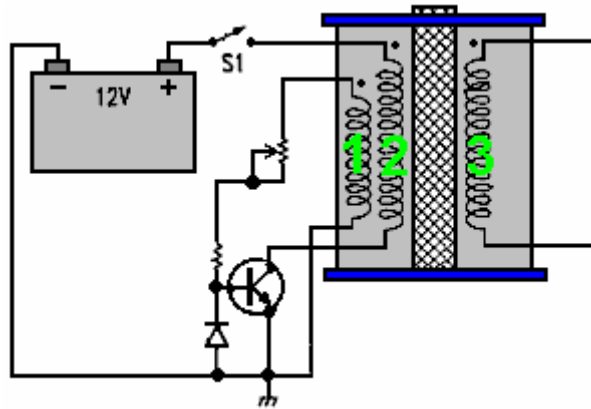

The rotor is desirable but not essential as the coils marked 1 and 2 can self-oscillate, and there can be any number of windings shown as 3 in the diagram. Winding 3 produces very short, sharp, high-voltage spikes, which is the essential part of the design. If those sharp pulses are fed to a lead-acid battery (instead of to a capacitor as shown above), then an unusual effect is created which triggers a link between the battery and the immediate environment, causing the environment to charge the battery. This is an amazing discovery and because the voltage pulses are high-voltage courtesy of the 1:1 choke coils, the battery bank being charged can have any number of batteries and be stacked as a 24-volt bank even though the driving battery is only 12 volts. Even more interesting is the fact that charging can continue for more than half an hour after the pulsing circuit is switched off.

It can be tricky to get one of these circuits tuned properly to work at peak performance, but when they are, they can have performances of COP>10. The major snag is that the charging mechanism does not allow a load to be driven from the battery bank while it is being charged. This means that for any continuous use, there has to be two battery banks, one on charge and one being used. A further major problem is that battery banks are just not suitable for serious household use. A washing machine draws up to 2.2 kilowatts and a wash cycle might be an hour long (two hours long if a "whites" wash and a "coloureds" wash are done one after the other which is not uncommon). During the winter, heating needs to be run at the same time as the washing machine, which could well double the load.

It is recommended that batteries are not loaded much beyond their "C20" rate, that is, one twentieth of their Amp-Hour nominal rating. Say that 85 Amp-Hour deep-cycle leisure batteries are being used, then the recommended draw rate from them is 85 Amps divided by 20, which is 4.25 amps. Let's push it and say we will risk drawing double that, and make it 8.5 amps. So, how many batteries would we need to supply our washing machine assuming that our inverter was 100% efficient? Well, 2,200 watts on a 12-volts system is $2,200 / 12 = 183$ amps, so with each battery contributing 8.5 amps, we would need $183 / 8.5 = 22$ large, heavy batteries. We would need twice that number if we were to treat them right, plus twice that again for household heating, say 110 batteries for an anyway realistic system. That sheer size of battery banks is not realistic for your average householder or person living in an apartment. Consequently, it appears that the Bedini pulse-charging systems are not practical for anything other than minor items of equipment.

However, the really important point here is the way that when these short pulses are applied to a lead-acid battery, a link is formed with the environment which causes large amounts of energy to flow into the circuit from outside. This is extra "free-energy". Interestingly, it is highly likely that if the pulses generated by Dave Lawton's water-splitter circuit shown above, were fed to a lead-acid battery, then the same battery-charging mechanism is likely to occur. Also, if a Bedini pulse-charging circuit were connected to a water-splitting cell like the Lawton cell, then it is highly probable that it would also drive that cell satisfactorily. Two apparently different applications, two apparently different circuits, but both producing sharp high-voltage pulses which draw extra free-energy from the immediate environment.

It doesn't stop there. Nikola **Tesla** introduced the world to Alternating Current ("AC") but later on he moved from AC to very short, sharp pulses of Direct Current ("DC"). He found that by adjusting the frequency and duration of these high-voltage pulses, that he could produce a whole range of effects drawn from the environment - heating, cooling, lighting, etc. The important point to note is that the pulses were drawing energy directly from the immediate environment. Leaving aside the advanced equipment which Tesla was using during those experiments and moving to Tesla's simple-looking 4-battery switch, we discover the same background operation of sharp

voltage pulses drawing free-energy from the environment.

Consider the circuit built and tested by the Electrodyne Corp. for a period of three years:

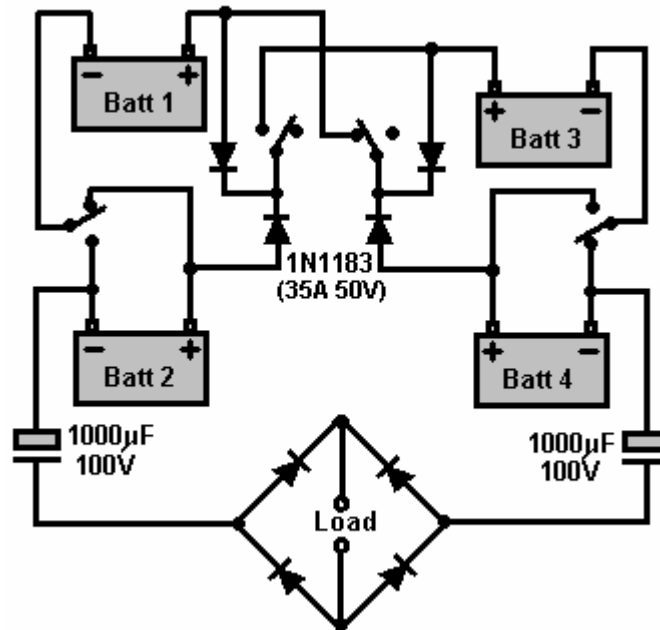

This simple-looking circuit needs to have an inductive load, preferably a motor, but that aside, consider the results of that very extended period of testing. If the switching rate and switching quality were of a sufficiently high standard, then the load could be powered indefinitely.

The batteries used were ordinary lead-acid batteries, and after the three years of tests, the batteries appeared to be in perfect condition. Their tests revealed a number of very interesting things. If the circuit was switched off and the batteries discharged to a low level, then when the circuit was switched on again, the batteries returned to full charge in under one minute. As no electrical charging circuit was connected to the system, the energy which charged those batteries had to be flowing into the batteries (and load) from outside the circuit. The similarity with the Bedini pulsed battery charger circuits immediately springs to mind, especially as no heating occurred in the batteries in spite of the massive charging rate. If the circuit was switched off and heavy current drawn from the batteries, then heat would be produced which is quite normal for battery discharging. The system operated lights, heaters, television sets, small motors and a 30-horsepower electric motor. If left undisturbed, with the circuit running, then each battery would charge up to nearly 36 volts with no apparent ill effects.

Here we have spectacular battery charging and performance, quite outside the normal range associated with these ordinary lead-acid batteries. Are they being fed very short, very sharp pulses, like the previous two systems? It would look as if they were not, but one other very interesting piece of information coming from Electrodyne is that the circuit would not operate correctly if the switching rate was less than 100 Hz (that is 100 switchings in one second). The Electrodyne switching was done mechanically via three discs mounted on the shaft of a small motor. It is distinctly possible that the brushes pressing on those rotating discs experienced the equivalent of "switch bounce" which plagues mechanical switches used with electronic circuits. Instead of a single, clean change over from Off to On states, there is a series of very short makes and breaks of the circuit. If this happened with the Electrodyne mechanical switching, then the circuit would have experienced very short, sharp electrical pulses at the instant of switching. The fact that the switching speed had to reach one hundred per second before the effect started happening is certainly interesting, though not proof by any means.

One other detail reported by the Electrodyne testers, is that if the switching speed exceeded 800 times per second, that it was "dangerous" but unfortunately, they didn't say why or how it was dangerous. It clearly was not a major problem with the batteries as they were reported to be in good shape after three years of testing, so definitely no exploding batteries there. It could well be as simple a thing that the voltage on each battery rose so high that it exceeded the voltage specifications of the circuit components, or the loads being powered, which is a distinct possibility. In my opinion, considering the way that the batteries responded, it would be perfectly reasonable to take it that short pulses were being generated by their mechanical system. If that is the case, then here is another system drawing free-energy from the environment via sharp voltage pulses.

Consider also, Bob **Boyce's** very effective electrolyser system, which achieves ten times the efficiency that

Faraday considered to be the maximum possible. Faraday was no fool and he performed very high-quality tests and experiments in a methodical way, making solid observations and drawing conclusions which were respected by his colleagues. Yet here we have Bob Boyce outperforming Faraday by a factor of ten times. Was Faraday wrong? Probably not. Is Bob wrong? Definitely not. How come then that they appear to disagree?

Well, the Boyce system pulls in additional energy from the immediate environment by applying very high quality pulsing to a toroidal transformer wound with three very accurately wound primaries and one very accurately wound secondary (D9.pdf has details of this). It also develops an oscillating magnetic field by using a hundred parallel, closely spaced steel plates. These magnetic oscillations enhance the process and place it outside the DC electrolysis which Faraday was examining. In passing, Shigeta Hasebe appears to get ten times the Faraday maximum on DC alone, but that is not the case as Shigeta uses strong permanent magnets to provide an additional energy input, so it is no longer strictly DC electrolysis.

The Boyce arrangement is like this:

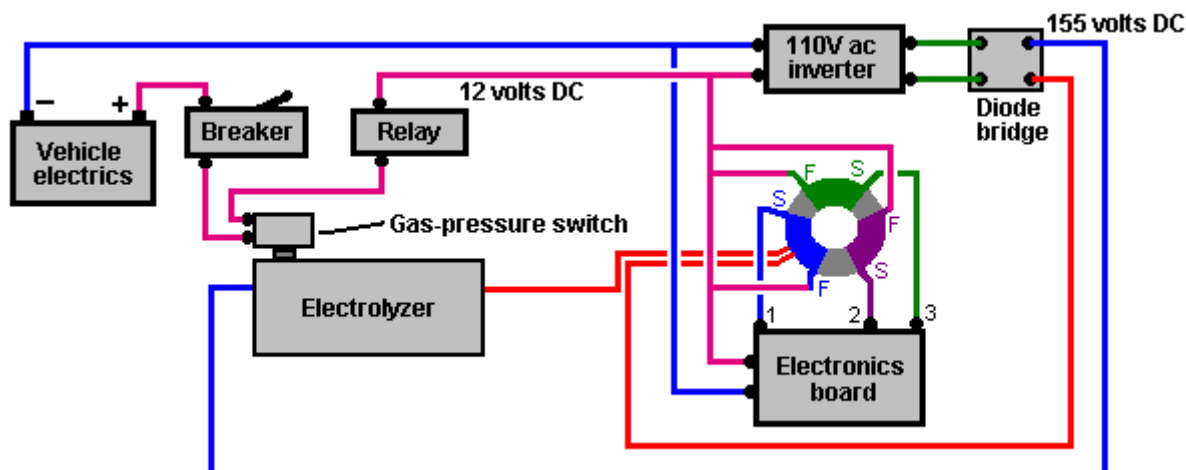

The output waveform from Bob Boyce's triple-oscillator board is sharpened up by the use of carefully chosen opto-isolators, and that output would almost certainly drive Dave Lawton's Meyer replication Water Fuel Cell. It would also be interesting to see if it has the same effect on battery recharging as the John Bedini pulse-charging circuits, as it is distinctly possible that it has. You will notice that Bob defeats the Faraday maximum output by careful construction of the electrolyser, plus one apparently simple electronics board and one apparently simple transformer. Again, these components call for very careful, high-quality construction as is common for most successful free-energy devices.

Serious warning needs to be given here. The combination of sharp pulsing and accurately wound toroid core composed of an iron powder matrix, draws in so much extra power from the environment that it is essential that it is only used with the electrolyser cell which is capable of soaking up excess energy surges. The extra energy drawn in is not always constant and surges can occur which can generate currents of 10,000 amps. It should be understood that this electrical current which we can measure is only the "losses" part of the real power surge which is in a form which we can't measure as we have no instruments which can measure it directly. Consequently, the actual environmental power surge is far, far in excess of this 10,000 amps. It is very important then, that the electronics board and toroidal transformer are NOT connected to other equipment "to see what will happen". Even more important is not to arrange a pulsed, rotating magnetic field in the toroid by sequential pulsing of coils spaced around the toroid. These arrangements can generate power surges so great that the excess power not soaked up by the circuit (especially after it's instantaneous burn-out) is liable to form the ground-leader of a lightning strike. Bob experimented with this and was hit by a direct lightning strike. He was very lucky to survive being hit and he now works in a workshop which has metal walls and roof, and lightning grounding at each corner of the building, plus a separate ground for the equipment inside the building. A device like this is not a toy, and it demonstrates the incredible level of free-energy which can be tapped by quite simple devices if you know what you are doing.

The power tube presented to the public by Ed Gray snr. operates by generating a series of very short, very sharp pulses using a spark gap. Tesla used this spark gap method with spark quenching provided by a strong magnetic field at right angles to the spark, in order to get really high-quality DC pulses with durations of one microsecond or less. Pulse trains of individual pulses with very short durations produce heat, spontaneous lighting, cooling, etc. as described in the D8.pdf document in this series, while the Ed Gray power tube is covered in the D1.pdf document. The power tube is placed around a heavy-duty copper conductor which is pulsed, unbalancing the zero-point

energy field and a tiny part of the resulting energy flow as the field moves back into equilibrium again, is captured by the surrounding perforated copper shells:

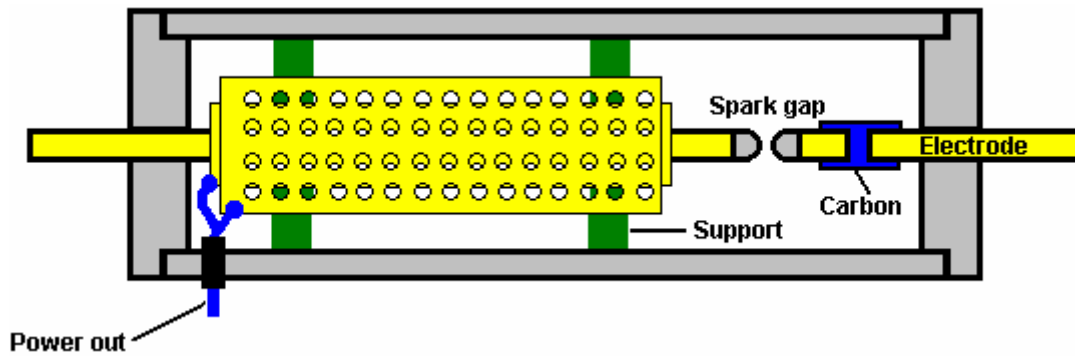

The power output available from the tube was said to be a hundred times the input power needed to make the device work.

So, a wide range of different devices have the same background technique for making them work. Meyer used the pulsing for water-splitting in a hydroxy gas cell. Bedini uses the pulsing to charge batteries with cold electricity. Tesla used the pulsing to charge batteries, provide heating, cooling and lighting. Boyce uses pulsing to obtain electrolysis at 1,000% of Faraday's stated maximum rate of electrolysis. Gray used the pulsing to capture cold electricity to drive a powerful electric motor. Many different applications all based on using very short, very sharp, high-voltage pulses.

The multi-strand inductor (coil) used to generate suitable voltage spikes are seen in the Meyer/Lawton Water Fuel Cell circuit, The Bedini pulse circuits and the Boyce toroidal transformer. As the water-splitting designs used by Dave Lawton and Bob Boyce has been covered in considerable detail in other documents in this set (D14.pdf and D9.pdf respectively) some additional detail on John Bedini's range of designs would be appropriate here. You should visit John's web site at <http://www.icehouse.net/john1/index11.html> and maybe join the support forum located at http://tech.groups.yahoo.com/group/Bedini_Monopole3/ where newcomers are welcome (books and DVDs are available for purchase at <http://www.energyfromthevacuum.com/>).

Any circuit which charges batteries places on the user, the requirement of understanding the basics of working with batteries. Ronald Knight who is a highly experienced professional in this field has requested that his advice be placed in this document in order to help people be safe when using batteries. He says:

I have not heard of anyone having a catastrophic failure of a battery case in all the energy groups to which I belong and most of them use batteries in the various systems which I study. However, that does not mean that it cannot happen. The most common reason for catastrophic failure in the case of a lead-acid battery, is arcing causing failure in the grids which are assembled together inside the battery to make up the cells of the battery. Any internal arcing will cause a rapid build up of pressure from expanding Hydrogen gas, resulting in a catastrophic failure of the battery case.

I am a former maintenance engineer for U.S. Batteries, so I can say with confidence, that when you receive a new battery from at least that manufacturer, you receive a battery which has undergone the best test available to insure the manufacturer that he is not selling junk which will be sent back to him. It is a relatively easy test, and as it takes place during the initial charge, there is no wasted time nor is there one battery that escapes the pass-or-fail test. The battery is charged with the absolute maximum current which it can take. If the battery does not blow up due to internal arcing during the initial charge it is highly likely that it will not blow up under the regular use for which it was designed. However, all bets are off with used batteries that have gone beyond their expected life.

I have witnessed several catastrophic failures of battery cases daily at work. I have been standing right next to batteries (within 12 inches) when they explode (it is like a .45 ACP pistol round going off) and have only been startled and had to change my under shorts and Tyvek jump-suit, and wash off my rubber boots. I have been in the charge room with several hundred batteries at a time positioned very closely together and have seen batteries explode almost every working day and I have never seen two side by side blow, nor have I ever seen one fire or any flash damage to the case or surrounding area as a result. I have never even seen a flash but what I have seen tells me it is wise to always wear eye protection when charging.

I have my new gel cells in a heavy plastic zip-lock bags partly unzipped when in the house and in a marine battery

box outside in the garage, that is just in the remote chance of catastrophic failure or the more likely event of acid on the outside of the battery case.

Vented batteries are always a risk of spillage which is their most common hazard, they should always be in a plastic lined cardboard or plastic box with sides taller than the battery and no holes in it. You would be surprised at how far away I have found acid around a vented lead acid battery under charge.

Have an emergency plan, keep a box of baking soda and a water source around to neutralise and flush the acid in case of spillage. It is best to have plastic under and around wherever your lead-acid batteries are located.

Ronald Knight gets about fifteen times more power from his Bedini-charged batteries than is drawn from the driving side of the circuit. He stresses that this does not happen immediately, as the batteries being charged have to be "conditioned" by repeated cycles of charging and discharging. When this is done, the capacity of the batteries being charged increases. Interestingly, the rate of current draw on the driving side of the circuit is not increased if the battery bank being charged is increased in capacity or in voltage.

Ron Pugh's Implementation of a John Bedini Rotor system

John Bedini's designs have been experimented with and developed by a number of enthusiasts. This in no way detracts from fact that the whole system and concepts come from John and I should like to express my sincere thanks to John for his most generous sharing of his systems. Thanks is also due to Ron Pugh who has kindly agreed for the details of one of his Bedini generators to be presented here. Let me stress again, that if you decide to build and use one of these devices, you do so entirely at your own risk and no responsibility for your actions rests with John Bedini, Ron Pugh, Patrick Kelly or anyone else. Let me stress again that this document is provided for information purposes only and is not a recommendation or encouragement for you to build a similar device.

Ron's device is powerful and it performs most impressively. Here is a picture of it rotating at high speed, where the speed of rotation prevent the magnets embedded in the rotor from being seen:

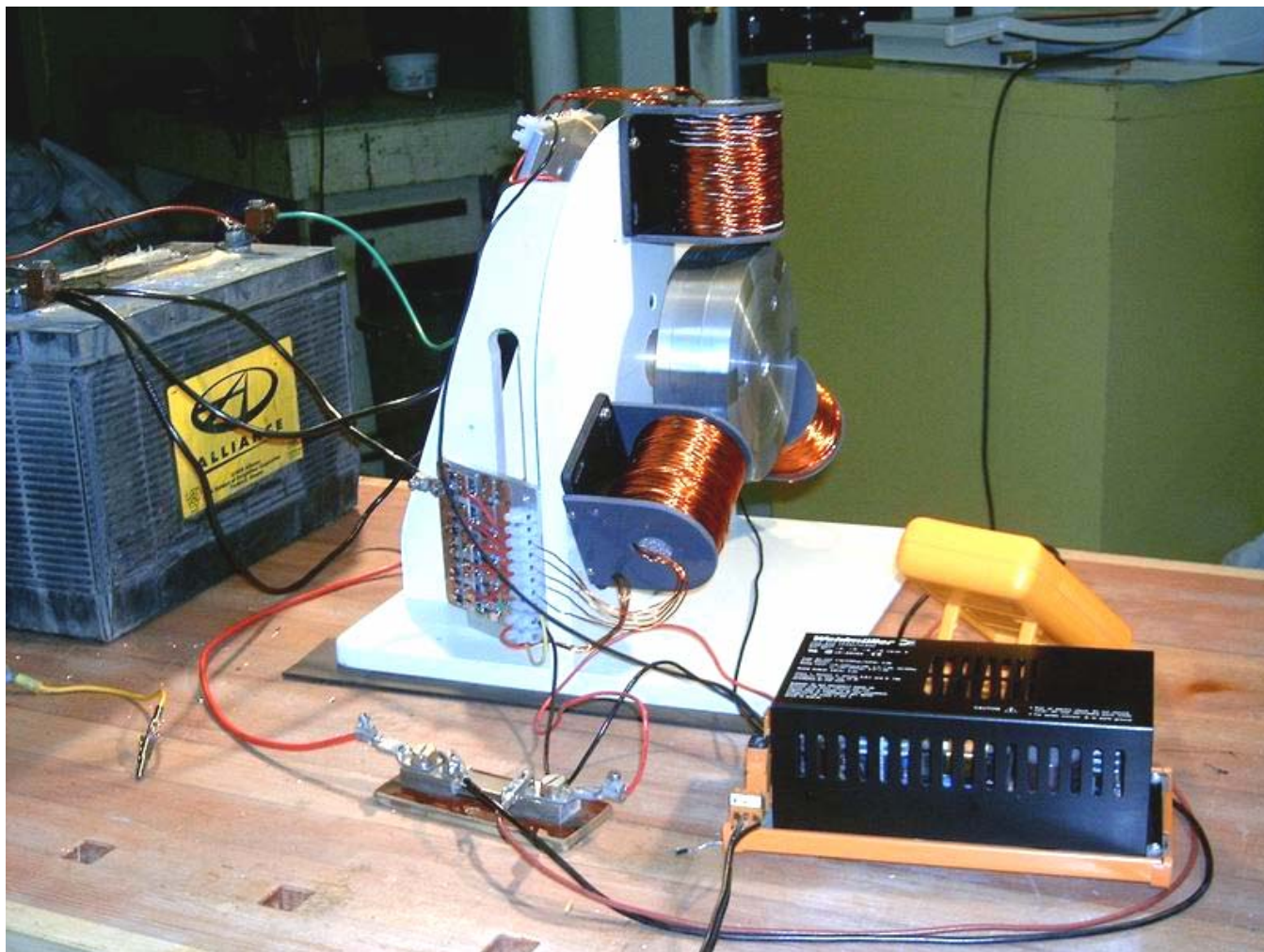

This is not a toy. It draws significant current and produces substantial charging rates. This is how Ron chose to

build his device. The rotor is constructed from aluminium discs which were to hand but he would have chosen aluminium for the rotor if starting from scratch as his experience indicates that it is a very suitable material for the rotor. The rotor has six magnets inserted in it. These are evenly spaced 60 degrees apart with the North poles all facing outwards.

The magnets are normal ceramic types about 22 mm wide, 47 mm long and 10 mm high. Ron uses two of these in each of his six rotor slots. He bought several spare ones and then graded all of them in order of their magnetic strength, which varies a bit from magnet to magnet. Ron did this grading using a gauss meter. An alternative method would have been to use a paper clip about 30 mm in size and measure the distance at which one end of the clip just starts to rise up off the table as the magnet is moved towards it:

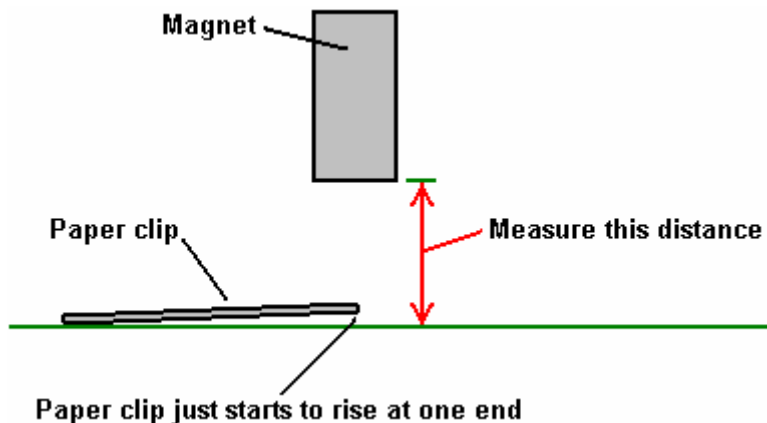

Having graded the magnets in order of strength, Ron then took the best twelve and paired them off, placing the weakest and strongest together, the second weakest and the second strongest, and so on. This produced six pairs which have fairly closely matching magnetic strengths. The pairs of magnets were then glued in place in the rotor using super glue:

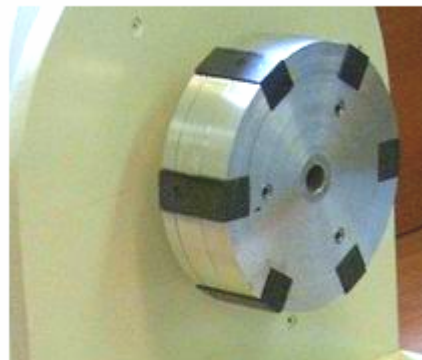
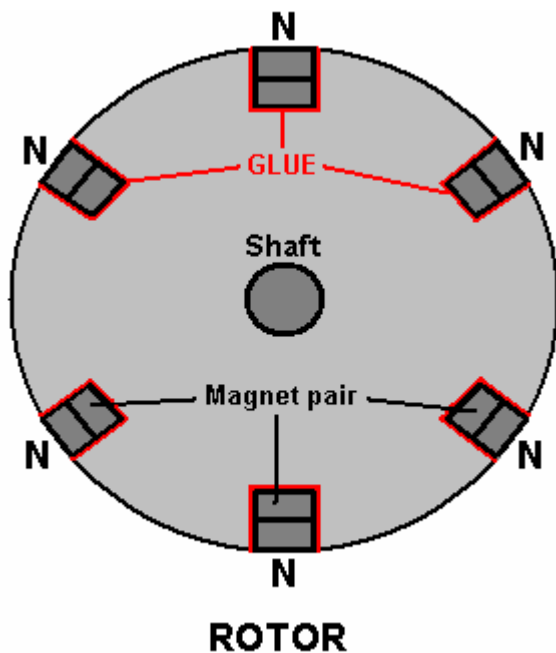

It is not desirable to recess the magnets though it is possible to place a restraining layer around the circumference of the rotor as the clearance between the magnet faces and the coils is about a quarter of an inch (6 mm) when adjusted for optimum performance. The North poles of the magnets face outwards as shown in the diagram above. If desired, the attachment of the magnets can be strengthened by the addition of blank side plates to the rotor which allows the magnet gluing to be implemented on five of the six faces of the magnet pairs:

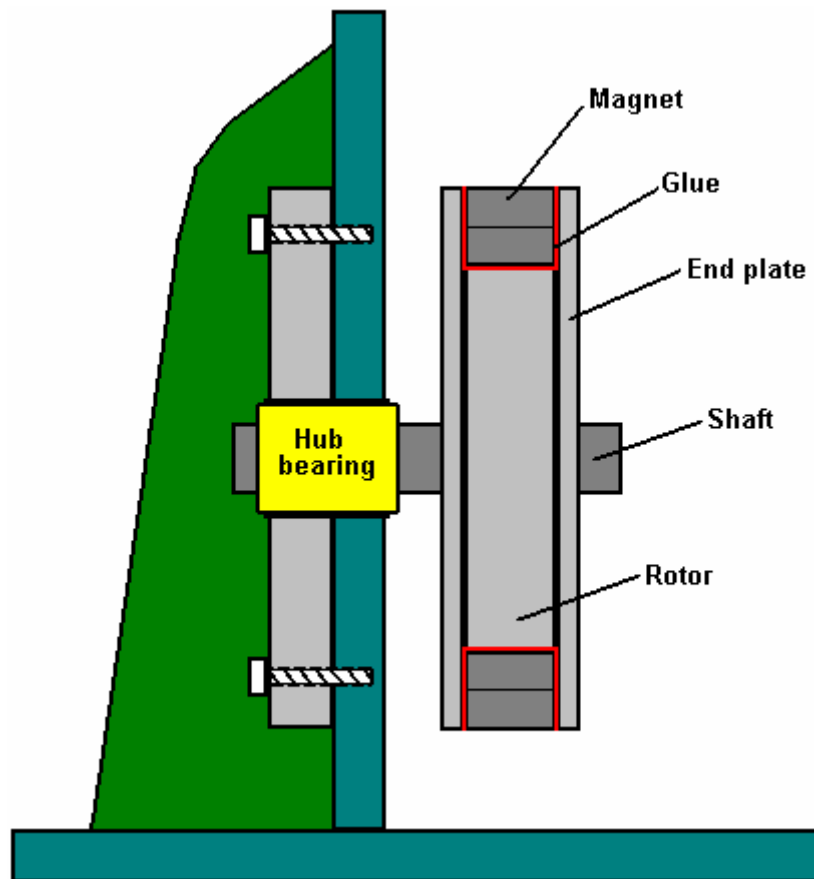

The magnets embedded in the outer edge of the rotor are acted on by wound “coils” which act as 1:1 transformers, electromagnets, and pickup coils. There are three of these “coils”, each being about 3 inches long and wound with five strands of #19 AWG (20 SWG) wire. The coil formers were made from plastic pipe of 7/8 inch (22 mm) outer diameter which Ron drilled out to an inner diameter of 3/4 inch (19 mm) which gives a wall thickness of 1/16 inch (1.5 mm). The end pieces for the coil formers were made from 1/8 inch (3 mm) PVC which was fixed to the plastic tube using plumbers PVC glue. The coil winding was with the five wires twisted around each other. This was done by clamping the ends of the five wires together at each end to form one 120 foot long bundle.

The bundle of wires was then stretched out and kept clear of the ground by passing it through openings in a set of patio chairs. A battery-powered drill was attached to one end and operated until the wires were loosely twisted together. This tends to twist the ends of the wires together to a greater extent near the end of the bundle rather than the middle. So the procedure was repeated, twisting the other end of the bundle. It is worth remarking in passing, that the drill turns in the same direction at each end in order to keep the twists all in the same direction. The twisted bundle of wires is collected on a large-diameter reel and then used to wind one of the “coils”.

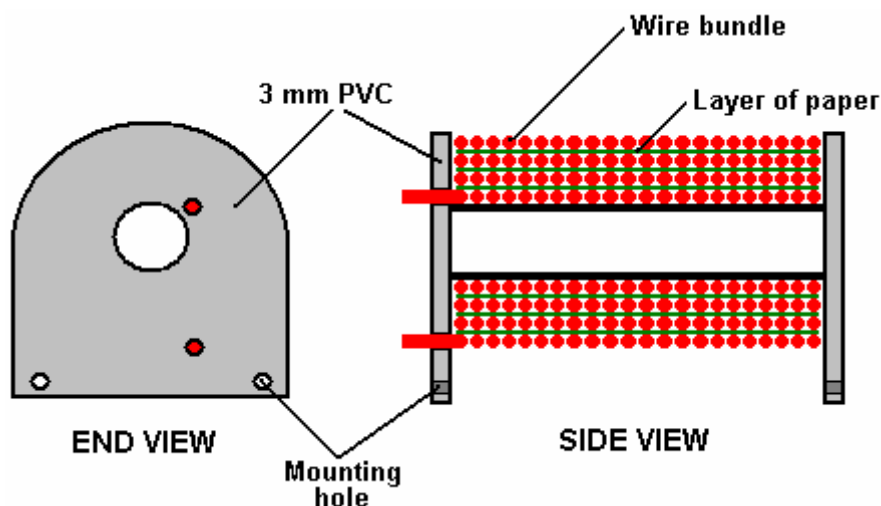

The coils are wound with the end plates attached and drilled ready to screw to their 1/4 inch (6 mm) PVC bases, which are the bolted to the 3/4 inch (18 mm) MDF supporting structure. To help the winding to remain completely even, a piece of paper is placed over each layer of the winding:

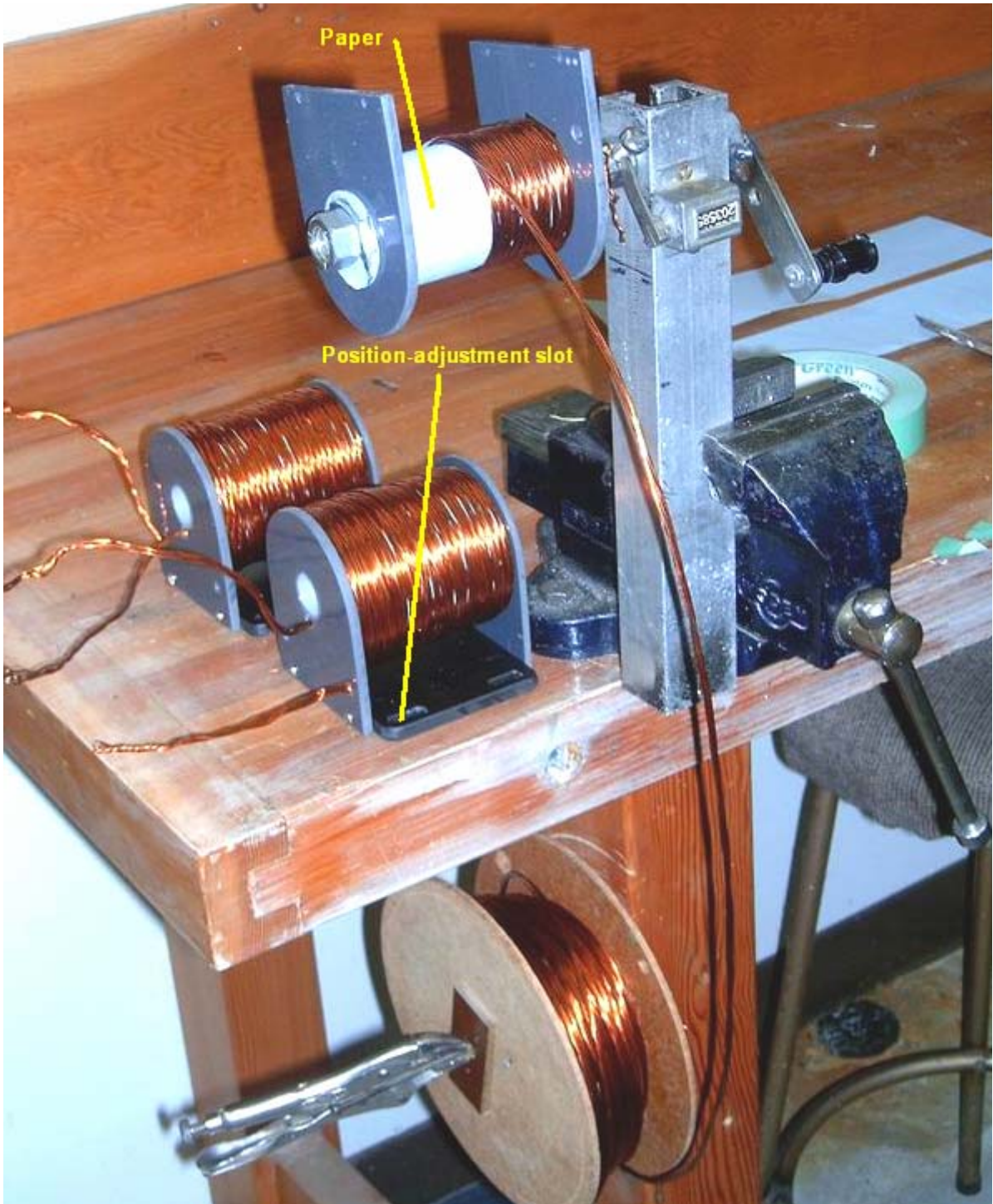

The three coils produced in this way were then attached to the main surface of the device. There could just as easily have been six coils. The positioning is made so as to create an adjustable gap of about 1/4 inch (6 mm) between the coils and the rotor magnets in order to find the optimum position for magnetic interaction. The magnetic effects are magnified by the core material of the coils. This is made from lengths of oxyacetylene welding wire which is copper coated. The wire is cut to size and coated with clear shellac to prevent energy loss through eddy currents circulating inside the core.

The coils are positioned at equal intervals around the rotor and so are 120 degrees apart. The end pieces of the coil formers are bolted to a 1/4 inch (6 mm) PVC base plate which has slotted mounting holes which allow the

magnetic gap to be adjusted as shown here:

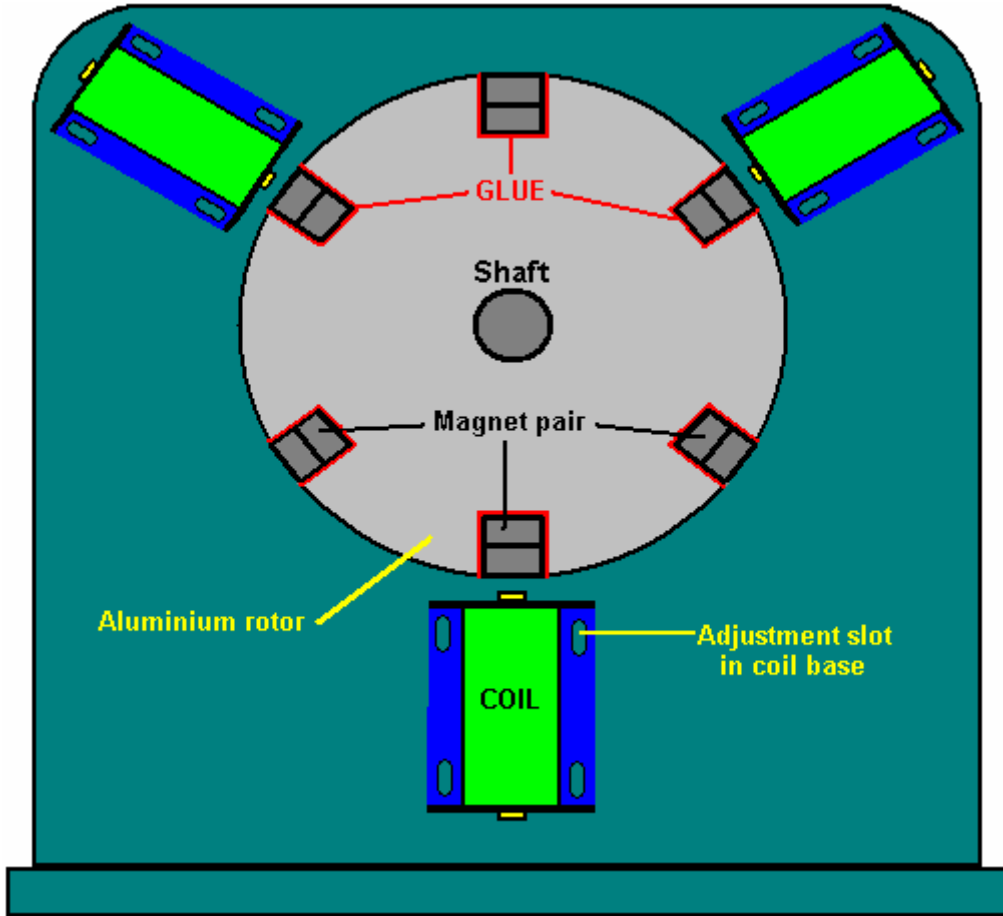

The three coils have a total of fifteen identical windings. One winding is used to sense when a rotor magnet reaches the coils during its rotation. This will, of course happen six times for each revolution of the rotor as there are six magnets in the rotor. When the trigger winding is activated by the magnet, the electronics powers up all of the remaining fourteen coils with a very sharp, pulse which has a very short rise time and a very short fall time. The sharpness and brevity of this pulse is a critical factor in drawing excess energy in from the environment. The electronic circuitry is mounted on three aluminium heat sinks, each about 100 mm square. Two of these have five BD243C NPN transistors bolted to them and the third one has four BD243C transistors mounted on it.

The metal mounting plate of the BD243 transistors acts as its heat sink, and while it looks as if they are bolted on to the large aluminium plate, there is actually an insulating pad underneath them as the heat generated is not excessive. BD243C transistors look like this:

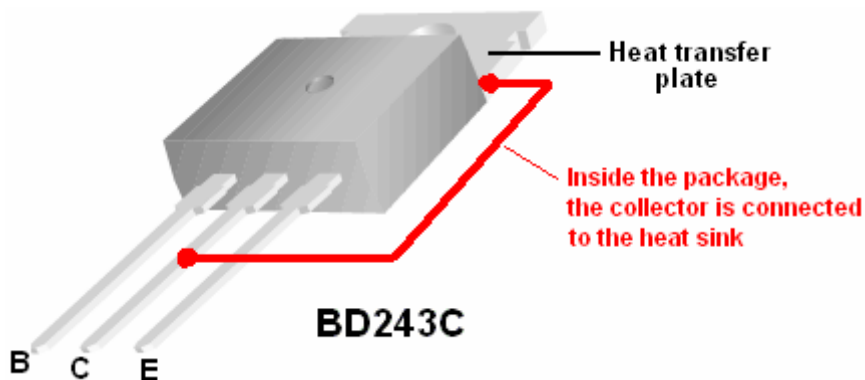

The circuit has been built on the aluminium panels so that the transistors can be bolted directly on to it, and provided with insulating strips mounted on top of it to avoid short circuits to the other components. Standard strip

connector blocks have been used to inter-connect the boards which look like this:

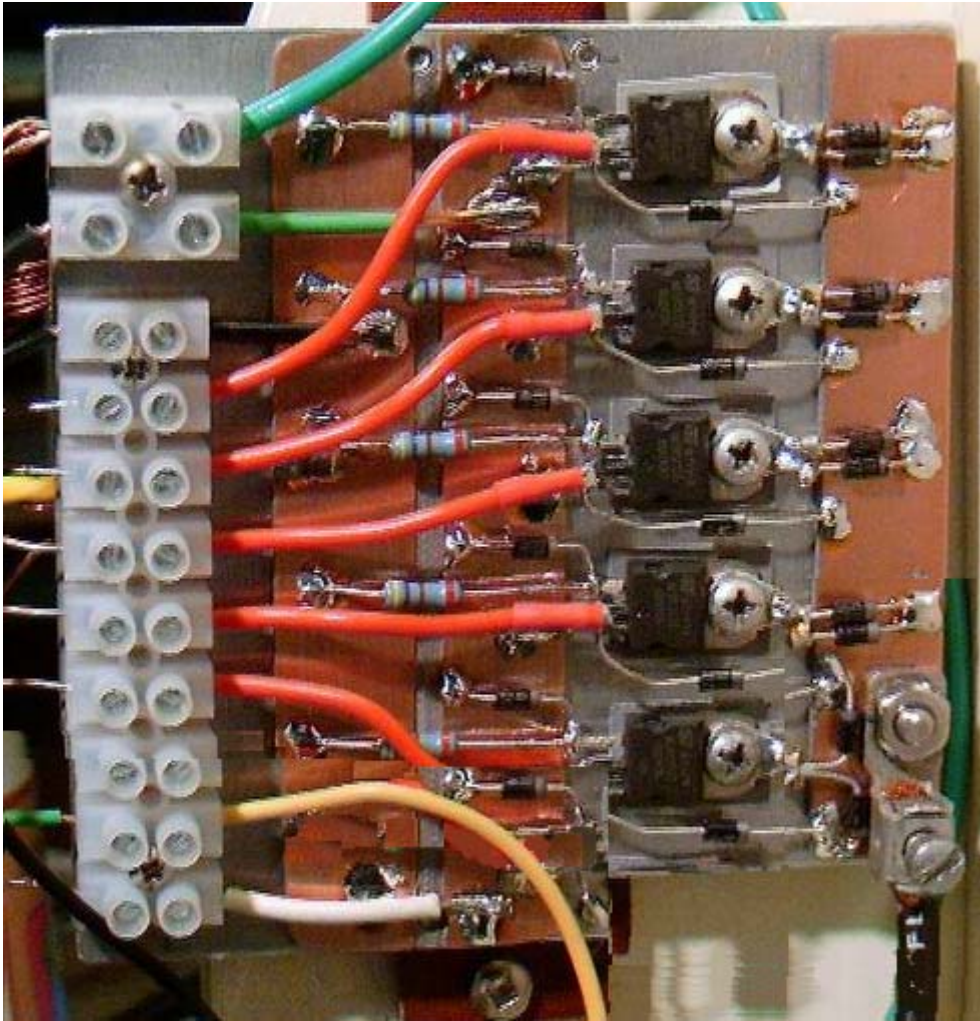

A circuit board of this general type is mounted at the rear of the unit:

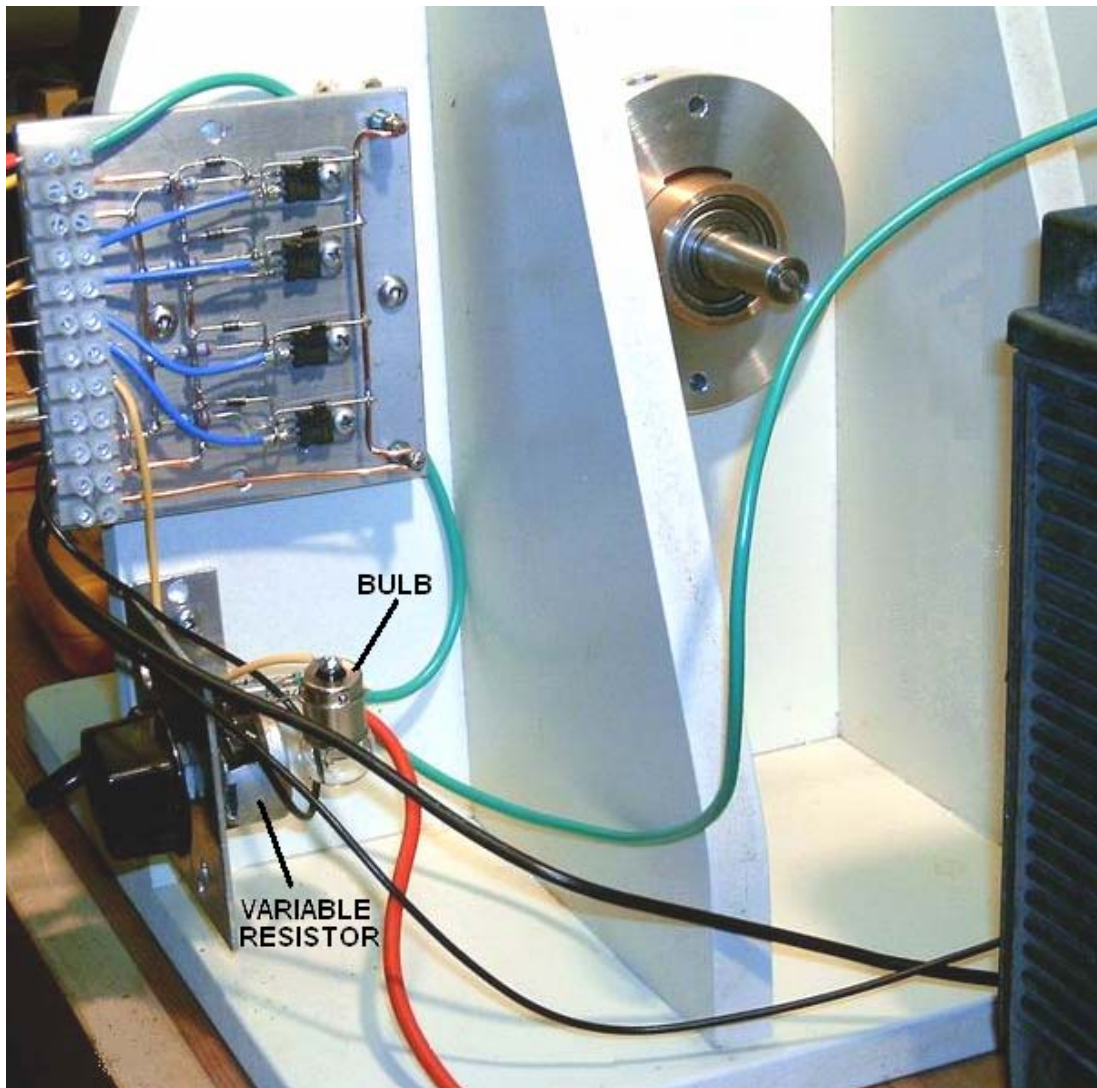

Although the circuit diagram shows a twelve volt drive supply, which is a very common supply voltage, Ron sometimes powers his device with a mains operated Power Supply Unit which shows a power input of a pretty trivial 43 watts. It should be noted that this device operates by pulling in extra power from the environment. That drawing in of power gets disrupted if any attempt is made to loop that environmental power back on itself or driving the unit directly from another battery charged by the unit itself. It may be just possible to power the unit successfully from a previously charged battery if an inverted is used to convert the power to AC and then a step-down transformer and regulated power rectification circuit is used. As the power input is so very low, off-grid operation should be easily possible with a battery and a solar panel.

It is not possible to operate a load off the battery under charge during the charging process as this disrupts the energy flow. Some of these circuits recommend that a separate 4 foot long earthing rod be used to earth the negative side of the driving battery, but to date, Ron has not experimented with this. In passing, it is good practice to enclose any lead-acid battery in a battery box. Marine chandlers can supply these as they are used extensively in boating activities.

When cutting the wire lengths for coating and pushing into the coil formers, Ron uses a jig to ensure that all of the lengths are identical. This arrangement is shown here:



The distance between the shears and the metal angle clamped to the workbench makes each cut length of wire exactly the required size while the plastic container collects the cut pieces ready for coating with clear shellac or clear polyurethane varnish before use in the coil cores.

Experience is particularly important when operating a device of this kind. The 100 ohm variable resistor should be a wire-wound type as it has to carry significant current. Initially the variable resistor is set to its minimum value and the power applied. This causes the rotor to start moving. As the rate of spin increases, the variable resistor is gradually increased and a maximum speed will be found with the variable resistor around the middle of its range, i.e. about 50 ohm resistance. Increasing the resistance further causes the speed to reduce.

The next step is to turn the variable resistor to its minimum resistance position again. This causes the rotor to leave its previous maximum speed (about 1,700 rpm) and increase the speed again. As the speed starts increasing again, the variable resistor is once again gradually turned, increasing its resistance. This raises the rotor speed to about 3,800 rpm when the variable resistor reaches mid point again. This is probably fast enough for all practical purposes, and at this speed, even the slightest imbalance of the rotor shows up quite markedly. To go any faster than this requires an exceptionally high standard of constructional accuracy. Please remember that the rotor has a large amount of energy stored in it at this speed and so is potentially very dangerous. If the rotor breaks or a magnet comes off it, that stored energy will produce a highly dangerous projectile. That is why it is advisable, although not shown in the above photographs, to construct an enclosure for the rotor. That could be a U-shaped channel between the coils. The channel would then catch and restrain any fragments should anything break loose.

If you were to measure the current during this adjustment process, it would be seen to reduce as the rotor speeds up. This looks as if the efficiency of the device is rising. That may be so, but it is not necessarily a good thing in

this case where the objective is to produce radiant energy charging of the battery bank. John Bedini has shown that serious charging takes place when the current draw of the device is 3 to 5+ amps at maximum rotor speed and not a miserly 50 mA draw, which can be achieved but which will not produce good charging. The power can be increased by raising the input voltage to 24 volts or even higher - John Bedini operates at 48 volts rather than 12 volts

The device can be further tuned by stopping it and adjusting the gap between the coils and the rotor and then repeating the start-up procedure. The optimum adjustment is where the final rotor speed is the highest.

The above text is intended to give a practical introduction to one of John Bedini's inventions. It seems appropriate that some attempt at an explanation of what is happening, should be advanced at this point. In the most informative book "Energy From The Vacuum - Concepts and Principles" by Tom Bearden (ISBN 0-9725146-0-0) an explanation of this type of system is put forward. While the description appears to be aimed mainly at John's motor system which ran continuously for three years, powering a load and recharging it's own battery, the description would appear to apply to this system as well. I will attempt to summarise it here:

Conventional electrical theory does not go far enough when dealing with lead/acid batteries in electronic circuits. Lead/acid batteries are extremely non-linear devices and there is a wide range of manufacturing methods which make it difficult to present a comprehensive statement covering every type in detail. However, contrary to popular belief, there are actually at least three separate currents flowing in a battery-operated circuit:

1. Ion current flowing in the electrolyte between the plates inside the battery. This current does not leave the battery and enter the external electronic circuit.
2. Electron current flowing from the plates out into the external circuit.
3. Current flow from the environment which passes along the external circuitry and into the battery.

The exact chemical processes inside the battery are quite complex and involve additional currents which are not relevant here. The current flow from the environment follows the electron flow around the external circuit and on into the battery. This is "cold" electricity which is quite different to conventional electricity and it can be very much larger than the standard electrical current described in conventional textbooks. A battery has unlimited capacity for this kind of energy and when it has a substantial "cold" electricity charge, it can soak up the conventional energy from a standard battery charger for a week or more, without raising the battery voltage at all.

An important point to understand is that the ions in the lead plates of the battery have much greater inertia than electrons do (several hundred thousand times in fact). Consequently, if an electron and an ion are both suddenly given an identical push, the electron will achieve rapid movement much more quickly than the ion will. It is assumed that the external electron current is in phase with the ion current in the plates of the battery, but this need not be so. John Bedini deliberately exploits the difference of momentum by applying a very sharply rising potential to the plates of the battery.

In the first instant, this causes electrons to pile up on the plates while they are waiting for the much heavier ions to get moving. This pile up of electrons pushes the voltage on the terminal of the battery to rise to as much as 100 volts. This in turn, causes the energy to flow back out into the circuit as well as into the battery, giving simultaneously, both circuit power and serious levels of battery charging. This over potential also causes much increased power flow from the environment into the circuit, giving augmented power both for driving the external circuit and for increasing the rate of battery charge. The battery half of the circuit is now 180 degrees out of phase with the circuit-powering half of the circuit.

It is important to understand that the circuit-driving energy and the battery-charging energy do **not** come from the sharp pulses applied to the battery. Instead, the additional energy flows in from the environment, triggered by the pulses generated by the Bedini circuit. In other words, the Bedini pulses act as a tap on the external energy source and are not themselves the source of the extra power.

If the Bedini circuit is adjusted correctly, the pulse is cut off very sharply just before the tapped energy inflow is about to end. This has a further enhancing effect due to the Lenz law reaction which causes an induced voltage surge which can take the over-voltage potential to as much as 400 volts. This has a further effect on the local environment, drawing in an even higher level of additional power and extending the period of time during which that extra power flows into both the circuit and the battery. This is why the exact adjustment of a Bedini pulsing system is so important.

It would be appropriate now to give some additional detail on the operation of the remaining item in this group; the

Tesla 4-battery switch:

3. Energy can be returned to a battery power source by its own load

Tesla 4-battery system, Ron Cole's 1-battery system

The Tesla 4-Battery Switch

Pupils in school are taught that if a bulb is connected across a battery, a current flows from the battery, through the bulb and back to the battery. This current causes the bulb to light, and after a time, the battery runs down and is no longer able to light the bulb. This is completely correct.

However, this teaching gives the wrong impression. It implies that the "work" done in lighting the bulb, uses up the electricity coming from the battery and that the battery somehow has a store of electricity, something like the sand in an hourglass or egg-timer, which when it runs out will no longer be able to light the bulb. Interestingly, those same teachers will show the correct picture of the circuit, drawing it like this:

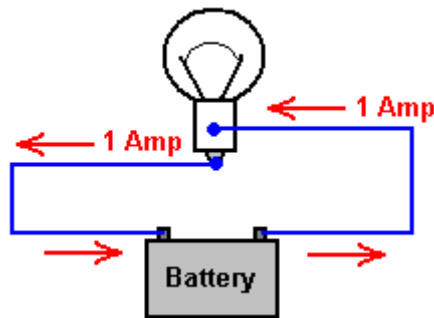

You will notice that the 1-amp current flowing out of the bulb is exactly the same as the 1-amp current flowing into the bulb. Exactly the same amount of current comes out of the bulb as the current which flows into the bulb. So, how much current is "used up" in doing the work of lighting the bulb? Answer: **None**. Energy is never destroyed, the most that can happen to it is that it gets converted from one form to another.

So why does the battery end up not being able to light the bulb any more? Well, that is a feature of the way that batteries operate. If the current flow is in one direction, then the battery gets charged up, and if it is in the other direction, then the battery gets discharged:

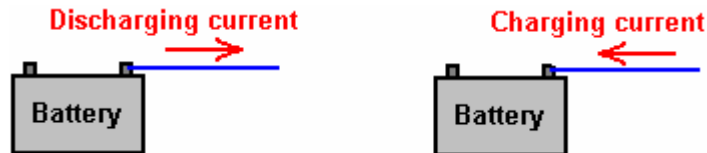

The battery getting run down, has nothing to do with the current flowing through the bulb, the battery would get run down if the bulb were left out of the circuit. The useful "work" of creating light by having the current flow through the bulb, does not "use up" any current, and more importantly, it does not "use up" any energy. Energy cannot be "used up" - it just gets transformed from one form to another. This is difficult to understand as we have been taught that we have to keep buying energy from the electricity supply companies to power our equipment. The false idea is that we buy the energy, and it then gets "used up" in the equipment, so we have to buy some more to keep the equipment going. We accept it because that's what we were taught. It isn't true.

The current flowing through the bulb can be arranged to be a charging current for another battery. It can both light the bulb and charge another battery without needing any extra current:

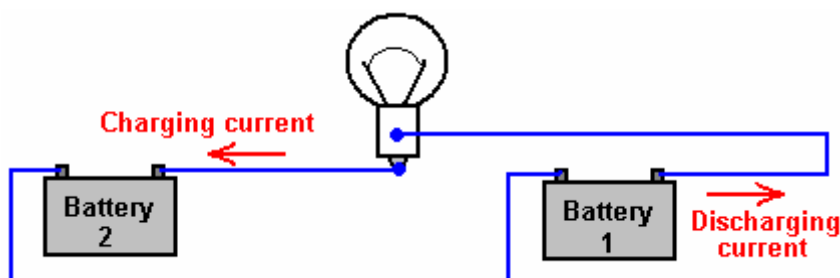

Here, the circuit is powered by battery 1 as before, but this time the current goes on to charge battery 2. Yes, battery 1 gets discharged just as before, but the plus side is that battery 2 is getting charged up all the time. The final step is to swap the batteries over:

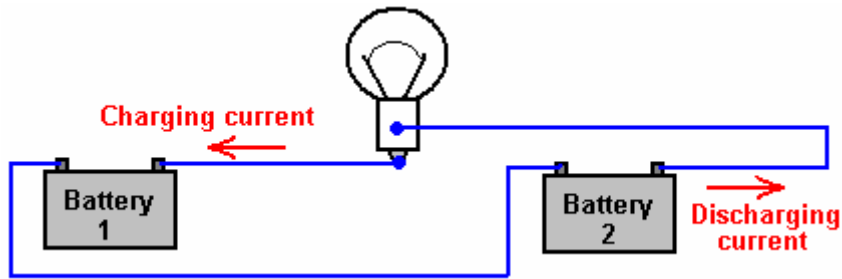

And now, the newly charged battery 2 lights the bulb and charges up battery 1 again. Seem impossible? Well it isn't. Nikola Tesla demonstrates this with his "4-battery switch" system where he chooses to use four identical batteries to implement this circuit:

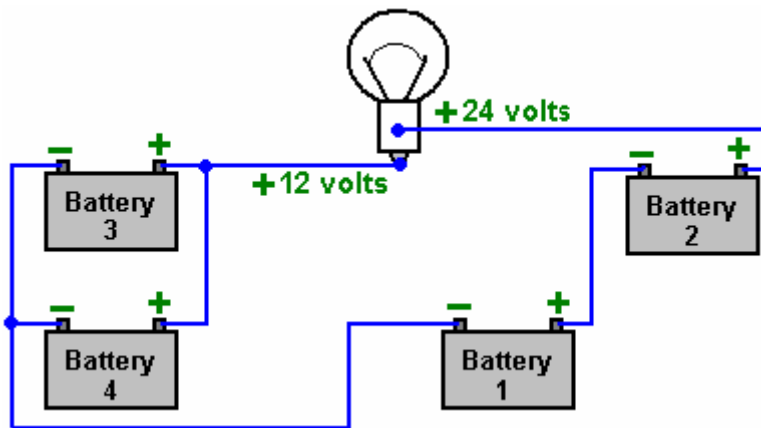

With 12-volt batteries as shown here, the bulb has the same 12 volts across it as it would have had with the single battery shown in the first diagram, as batteries 1 and 2 are wired "in series" to give 24 volts, while batteries 3 and 4 are wired "in parallel" to give 12 volts. The Tesla switch circuit swaps the batteries over with 1 and 2 taking the place of 3 and 4, hundreds of times per second. If you wire a simple manual change-over switch and use it to change the battery arrangement as shown above, tests show that the batteries can power the light for a longer time than if they were not switched over. The snag is that batteries are not 100% efficient and so you can only take about half of the charging current back out of the battery again. For a Tesla 4-battery switch to operate indefinitely, there has to be inflow of outside energy to offset the poor efficiency of a lead-acid battery. NiCad batteries are more efficient and so they are sometimes used in this circuit, where they can work well.

The Practical Details:

There is another important factor involved in battery-charging circuits to be used with normal lead-acid batteries and that is the characteristics of the materials involved. The charging process in this switching circuit is carried out by electrons flowing down the connecting wire and into the battery. The electrons flowing along the outer surface of the wire, move very rapidly indeed. The main current inside the battery is carried by the charged ions inside the lead plates inside the battery. These ions are hundreds of thousands of times heavier than the electrons. This doesn't matter at all once the ions get moving, but in the initial split second before the ions get going, the incoming electrons pile up like in a traffic jam tail-back. This pile-up of electrons pushes up the voltage on the terminal of the battery, well above the nominal battery voltage, and so the charging starts off with a high-voltage, high-current pulse into the battery.

This is not normally noticed when using a standard mains-powered battery charger, as switch-on only occurs once during the whole charging process. In the Tesla switch shown here, and in the Bedini circuits shown earlier, this is not the case. The circuit takes advantage of this difference in momentum between the electrons and the lead ions, and uses it repeatedly to great advantage. The technique is to use very short duration pulses all the time. If the pulses are short enough, the voltage and current drive into the receiving battery is far greater than a quick glance at the circuit would suggest. This is not magic, just common-sense characteristics of the materials being used in this circuit.

A person unfamiliar with these systems, seeing John Bedini's many advanced circuits for the first time, might get the impression that they are just crude, roughly-built circuits. Nothing could be further from the truth. John often uses mechanical switching because it gives very sharp switch-on and switch-off times. John is a complete master of this circuitry and knows exactly what he is doing

The Electrodyne Corporation tested the Tesla 4-battery circuit over a period of three years. They found that at the end of that period, the batteries did not show any unusual deterioration. The batteries used were ordinary lead-acid batteries. The system operated lights, heaters, television sets, small motors and a 30-horsepower electric motor. If the batteries were run down to a low level and then the circuit switch on with a load, the recharging of the batteries took place in under one minute. No heating was experienced during this rapid charging. Heat was only produced during discharge cycles. If left undisturbed, each battery would charge up to nearly 36 volts. Control circuitry was developed to prevent this over-charging. They used mechanical switching and stated that below 100 Hz there was not much advantage with the circuit and above 800 Hz it could be dangerous.

They didn't mention why they consider that higher rates of switching could be dangerous. If we consider what exactly is happening, perhaps we can work out why they said that. The charging situation is like this:

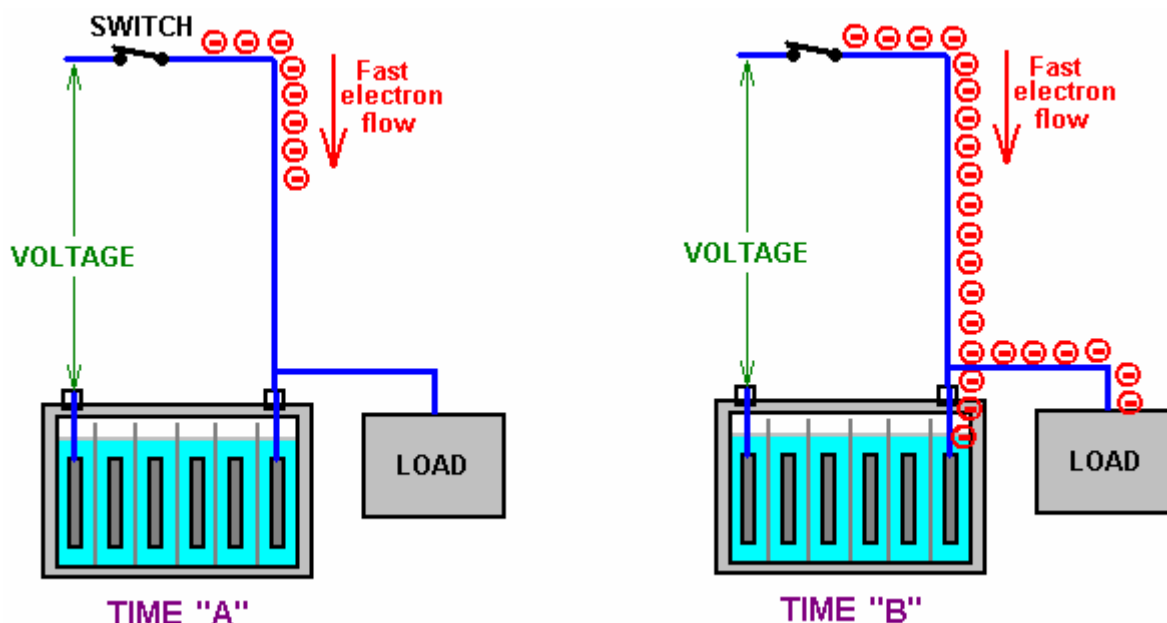

At Time "A" the switch closes, connecting a voltage source (battery, charged capacitor, or whatever) to a lead-acid battery. Electrons start flowing down the outside of the connecting wire. Being very light and having little obstruction, they move very fast indeed (the electrons inside the wire only move a few inches per hour as getting through the wire is difficult). All goes well until Time "B" when the leading electrons reach the lead plates inside the battery. Here, they have a problem, because the current flow through the plates is carried by lead ions. Lead ions are very good at carrying current, but it takes them a split second to get going due to their inertia. That split second is critical and it opens the door to free-energy. In that split second, the electrons pile up because they are still arriving down the wire at very high speed. So, at Time "C" they have built up into a large body of electrons.

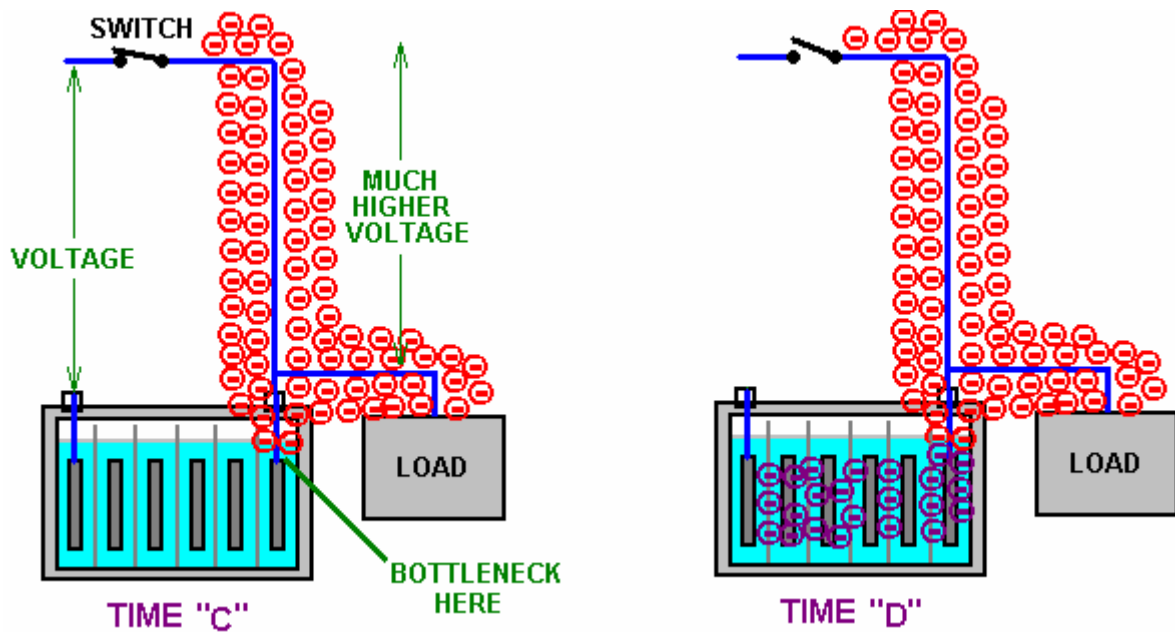

This large body of electrons has the same effect as if there had been a sudden connection to a much higher voltage source capable of supplying a much higher current. This situation only lasts for a very short time, but it has three very important effects. Firstly, at Time "D", it drives a much larger current into the battery than could reasonably be expected from the original voltage source. Secondly, this high voltage pulse alters the Zero-Point Energy field (the space-time continuum) in which the circuit is located, causing extra energy to flow into the circuit from the outside environment. This is a bit like sunshine generating current flow in an electric solar panel, but instead of visible sunshine, the energy flow is not visible to us and we have no instruments which react to this excess energy. Thirdly, the excess energy flows into the battery, charging it much more than would be expected, and at the same time, some of the excess energy flows into the load, powering it as well, and further, some of the flow goes back into the driving circuit, lowering its current draw.

Remember Dave Lawton's Water Fuel Cell? Well Dave also connects a bulb across the cell to extract additional energy:

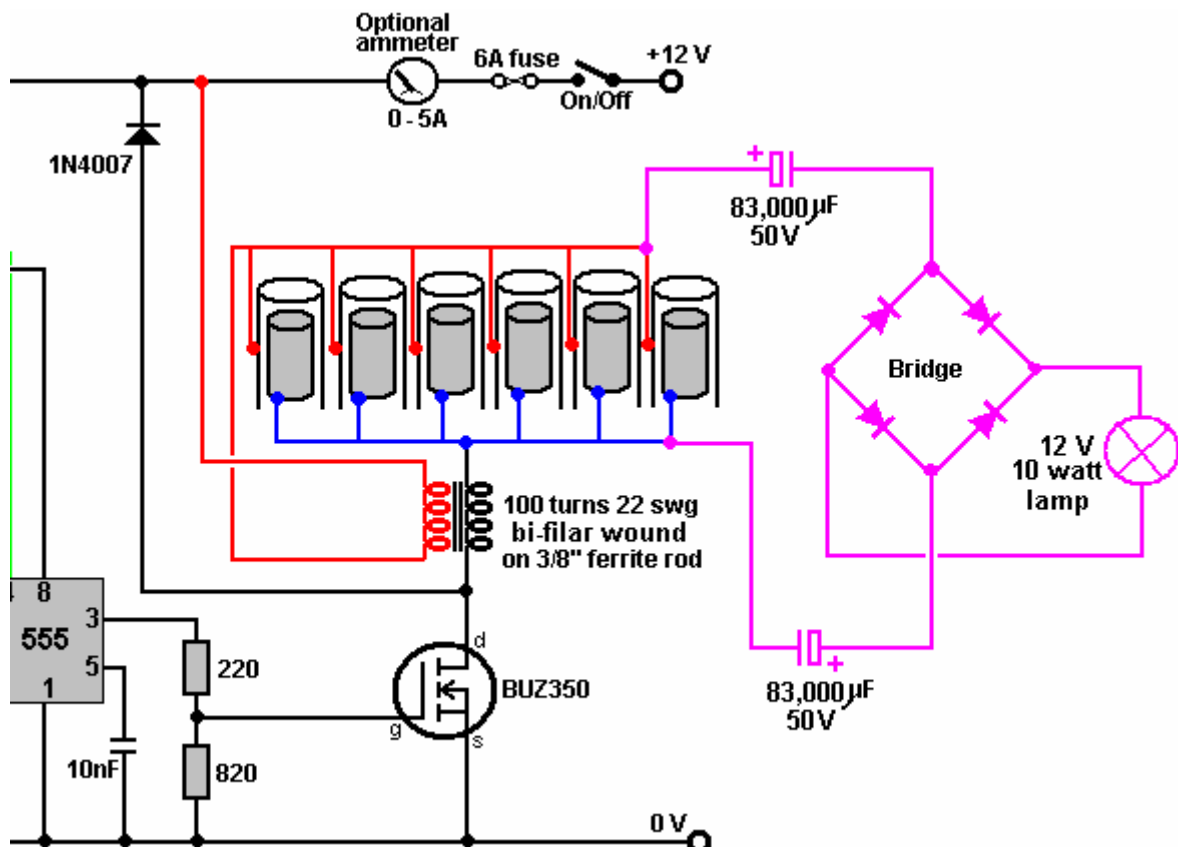

A really interesting feature of this extra power draw-off is that when Dave adjusts the frequency to the optimum value, the supply voltage remains unchanged but the input current drops noticeably and the brightness of the lamp increases markedly. Less input power at the same time as greater output power - the circuit hasn't changed, so where is the extra power coming from? One possibility is certainly that it is flowing in from the environment.

So, returning to our excess energy is collected from the environment and used to both charge the battery and at the same time, perform useful work. The old saying "you can't have your cake and eat it" just does not hold in this situation as that is exactly what happens. Instead of the battery being run down from powering the load, the load gets powered **and** the battery gets charged up at the same time. This is why, with this system, a discharged battery can be used to apparently run a motor. It works because the plates in the discharged battery are made of lead which forms a bottleneck for the electron flow, causing the environment to charge the battery and run the load at the same time. That is why you get what looks like the magical effect of a discharged battery appearing to power a load. In passing, the more discharged the battery, the faster it charges as the environment adjusts automatically to the situation and feeds greater power into a flat battery. The environment has unlimited power available for use. John Bedini who is expert in this field has had motors running continuously for three or more years with the battery never running down and the motor doing useful work all the time. Great battery? No, - great environment !!

Not necessarily exactly the same effect, but Joseph Newman's motor exhibits this same effect, much to the discomfort of a conventionally taught scientist, who measured the motor at a minimum of 400% "efficiency" (really COP=4) and probably nearer 800% when all the major factors were taken into account. One thing which really bothered him was that when powering the motor on almost completely discharged dry cell batteries, the voltage measured at the motor was some three times the voltage at the batteries. That is very upsetting for a scientist who is not aware of the zero-point energy field and considers most systems to be "closed" systems, when in fact, there are practically no "closed" systems in our universe. Surprise, surprise, the Newman motor operates on electrical pulses.

Anyway, returning to the Tesla 4-battery switch. For the vital build up of excess electrons to take place, the switch closure has to be very sudden and very effective. A thyristor or "SCR" might be suitable for this, but the sharp switching of a PCP116 opto-isolator driving an IRF540 FET is impressive and a TC4420 FET-driver could substitute for the opto-isolator if preferred. It is likely that the Tesla 4-battery switch circuit switching in the 100 Hz to 800 Hz region operates in this way.

This drawing in of excess energy from the environment can be further enhanced by suddenly cutting off the electron flow from the original voltage source while the excess electron pile-up is still in place. This causes a sudden (very brief) further surge in the excess power, building up the voltage and current even further and increasing the battery charging and load powering drive.

An even greater effect can be had if the next, short, sharp pulse is applied to the battery/load combination, just before the effect from the last pulse dies away. It may be that this is the situation which the Electrodyne Corporation people encountered when the pulse rate went over the 800 Hz rate. It may not be so much a case that the battery and load could not take the power, but more a case that the components which they were using were not rated high enough to carry that level of power. They do mention that if they went further, that they found that some of their circuit components started failing through not having high enough ratings (notice that the output capacitors are rated at 100 volts which is eight times the nominal battery voltage). This was hardly a problem, considering that they had 12-volt batteries operating happily at 36-volts if they wanted that. They ended up building circuitry to hold the voltages down to a convenient level.

To summarise the situation. The Tesla 4-battery switch appears to do the impossible through:

1. Catching the current coming out of the load and using it to charge another battery instead of wasting it.
2. Providing very short, sharp, and rapid switching pulses which exploit the momentum of the lead-ions current flow.
3. Pulling extra energy in from the local environment to both charge the batteries and power the load at the same time

This leaves aside the possibility of two further gains available through very precise timing of the switching pulses (mainly to make the power available more easily and cheaply handled). So, it should be borne in mind that the practical issues involved in getting this circuit operating effectively are primarily about very fast, clean and well-timed switching. Stranded, very large diameter, high-current rated wire will be helpful in getting the draw of excess energy into the circuit.

Here is the switching sequence for the Tesla 4-battery switch system:

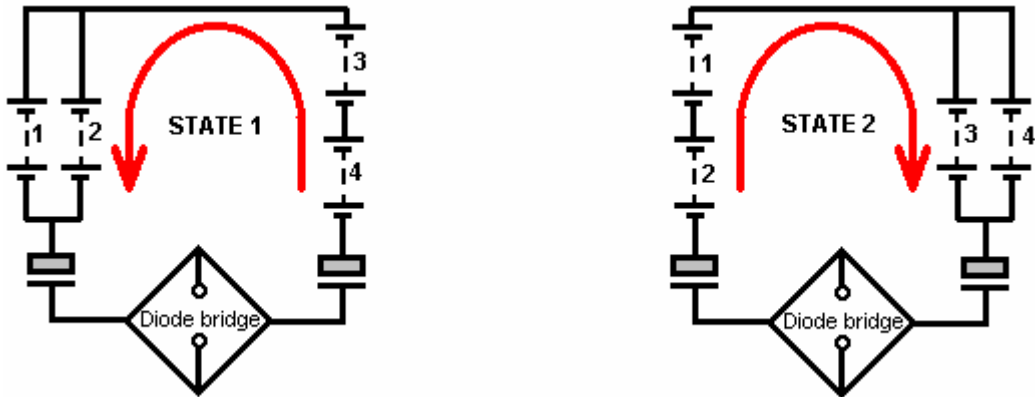

As you can see, this is essentially the same circuit with batteries 1 and 2 swapping over with batteries 3 and 4. But he has added in two capacitors and a diode bridge of four diodes to power the “load” which needs to be inductive for this circuit (transformer, motor, etc.). The circuit used by the Electrodyne Corp. testers was:

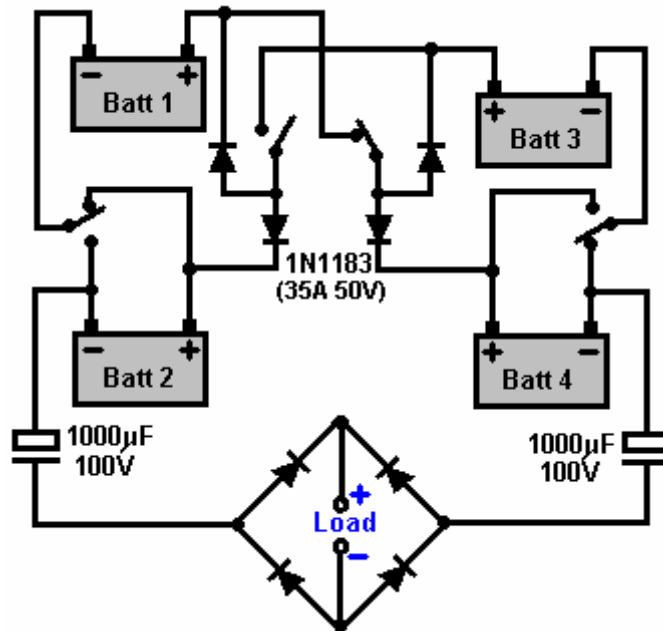

This circuit was reported to have excellent results using six On/Off switches on a motor-driven cam arrangement:



Here three discs are mounted on the shaft of a motor as shown here. These are insulated from each other and the conducting sectors are aligned, and so are the brushes. The arrangement gives a mechanical switching such that when the upper brushes are short-circuited together, the lower brushes are open-circuit. As there is a requirement for an inductive load for this circuit, the motor of a mechanical switching system could well form part of the load. Many people prefer solid-state switching to mechanical switching and so set out to design suitable circuits. It needs to be borne in mind that a very precise 50% Mark/Space ratio is essential and that may not be so easy to arrange. The common idea of using mechanical relays is not very practical. Firstly, relays have trouble switching at the speeds suggested for this circuit. Secondly, with a contact life of say, two million and a switching speed of just 100 times per second, the relays would reach their projected lifespan after two weeks of operation, which is not

a very practical option.

To get an exact 50% Mark/Space ratio, possibly the following style of circuit could be used with a 10-turn preset resistor in position "A":

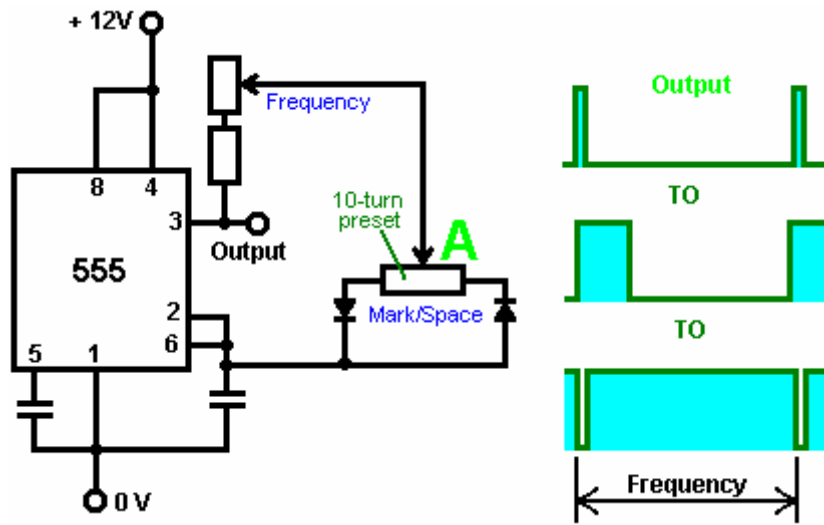

Here, the frequency is not noticeably affected by adjustment through a very wide range of Mark/Space settings. The output from Pin 3 needs to drive a very sharp switching combination such as a TC4420 FET driver connected to IRF540 FETs.

As the circuit diagram used by the Electrodyne Corp. people is a little difficult to follow, perhaps the following diagrams may help by showing the current flow during the two states:

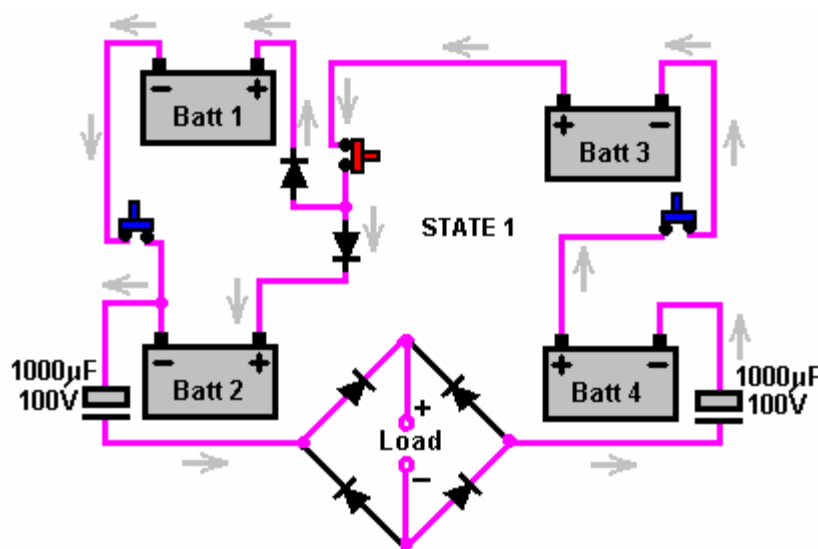

Here, batteries 1 and 2 are wired across each other while batteries 3 and 4 are wired in series (in a daisy-chain). This needs three On/Off switches and the two diodes are inserted so that the plus terminal of battery 1 is not permanently connected to the plus terminal of battery 2, because in State 2, that connection must not be made.

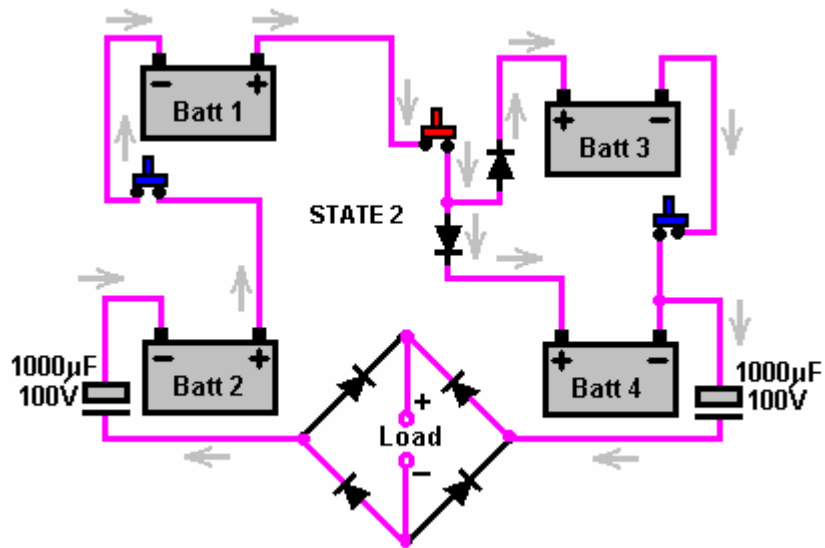

The State 2 wiring is almost identical, requiring another three On/Off switches and two diodes to avoid a permanent link between the plus terminals of batteries 3 and 4.

Here is a suggestion for doing that with PCP116 fast-operating opto-isolators:

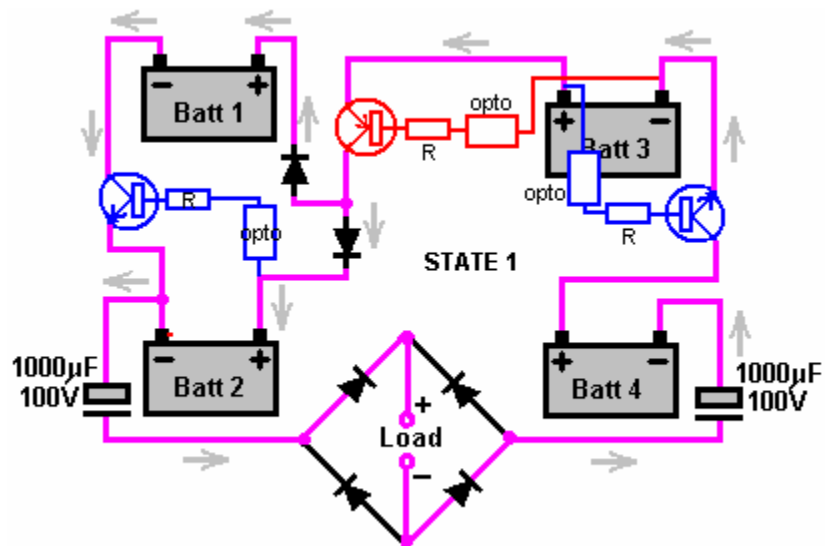

Each of the three mechanical switches are replaced with a transistor - one PNP type and two NPN type. These need to be able to handle 30 amps, so although not shown here, they will probably be Darlington pairs with the low gain of the high-power transistor being boosted by the additional gain of a driver transistor, perhaps something like a 2N3055 / 2N2222A combination. The transistor base current comes via a limiting resistor fed from an appropriate battery terminal a fixed 12 volts above it. The switching is controlled via an opto-isolator and the three opto isolators which switch together (shown above) are driven from one side of an astable multivibrator. The other three opto-isolators needed to perform the switching for State 2, will be Off during State 1, so they will be driven by the inverted version of the same oscillator waveform. This ensures that three will be On and three will be Off at all times.

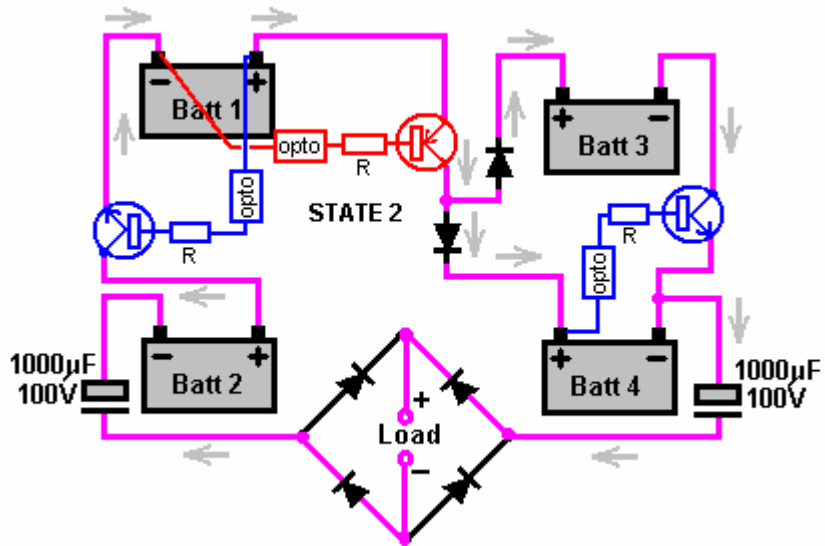

The suggested transistor switching for the State 2 situation is shown above. This is just an attempt to perform the switching with the most simple components available, and has been shown to work in practice.

The mechanical changeover switch can be replaced with transistors:

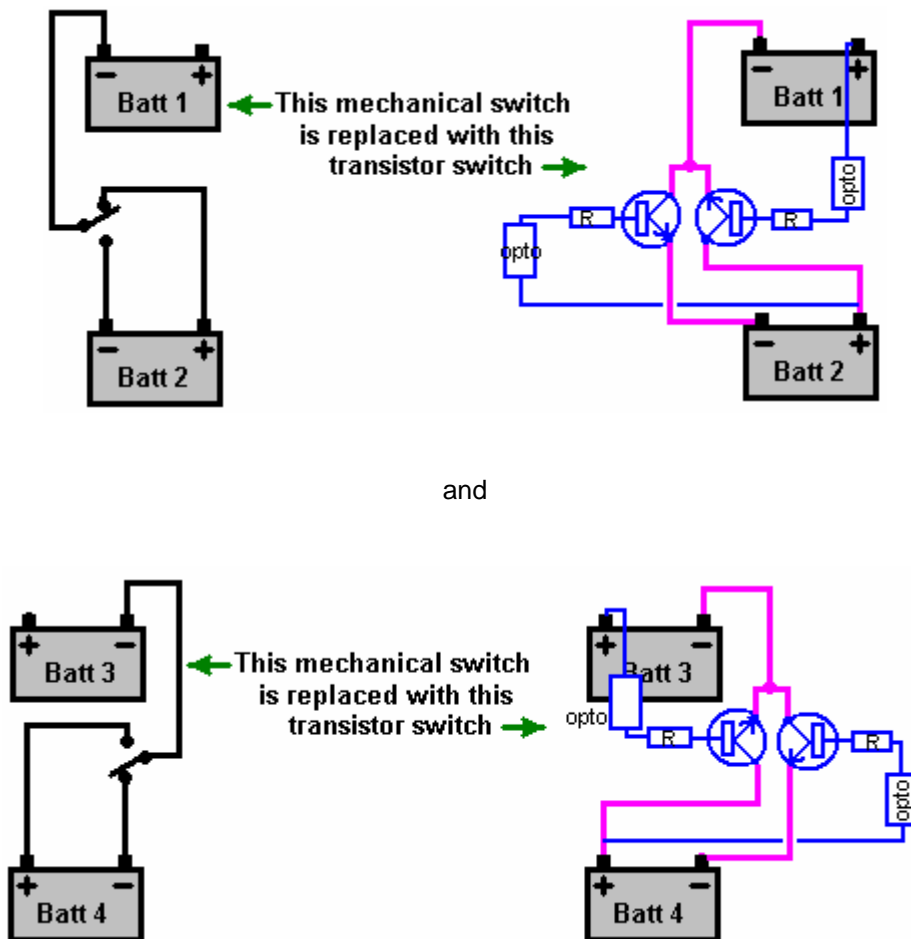

The Electrodyne Corp. experience indicates that it is likely that additional circuitry will be needed to cut off the extra power when the energy in the batteries rises to the point where it could endanger the equipment which it is powering or the components in the circuitry.

The electronics tutorial which forms part of this set of documents shows the principles which can be used for the

design and construction of this kind of circuitry. It might be sensible to have the control circuitry kick in at fourteen or fifteen volts and drop out again when the battery voltage drops back to 12.5 volts or so.

This switching circuit is said to be able to power its load indefinitely. It is also said that if one of the batteries is fully discharged, or nearly fully discharged, then putting it in any of the four positions returns it to full charge within one minute.

The connecting wires should be at least 30 Amp current carrying capacity and the individual diodes and the diode bridge are rated at 35 Amps 50 Volts. The circuit is intended for use with lead/acid batteries but it has been used successfully with rechargeable NiCad batteries. The circuit provides about 12 volts as the output, so mains equipment would be operated using a standard, commercial "inverter" which converts this low DC voltage to normal mains AC voltage capable of powering TV sets, DVD recorders, or whatever.

There have been various different versions of the Tesla 4-battery switch circuit. Some of these show additional diodes, making an absolutely symmetrical circuit where the current flow can continue even if the load is disconnected, as shown here:

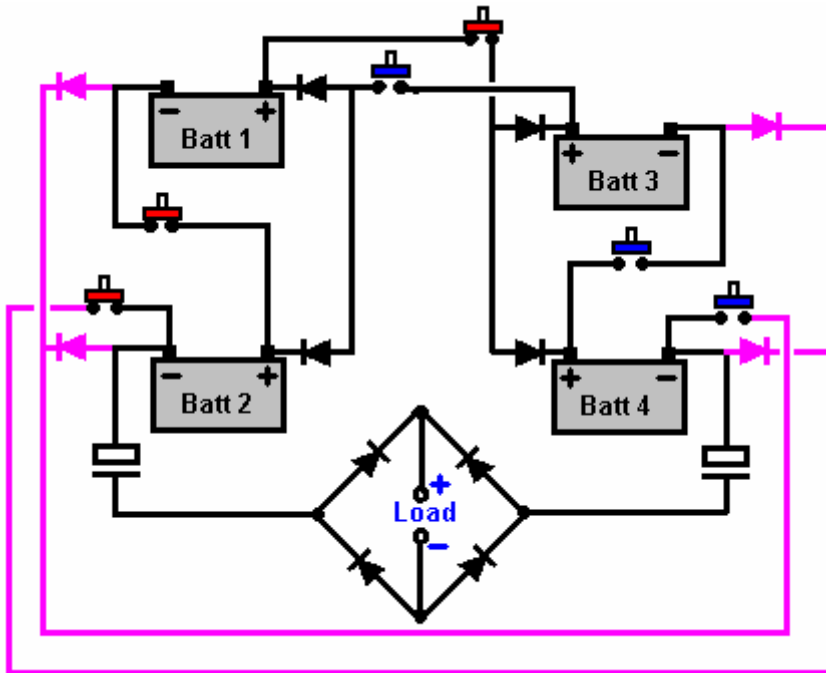

As this circuit relies on 24 volts on one side and 12 volts on the other, it would be perfectly feasible to implement it with just three batteries, as suggested by John Bedini.

If we are just looking for sharp spikes to charge a battery, then perhaps the following circuit might be effective for that:

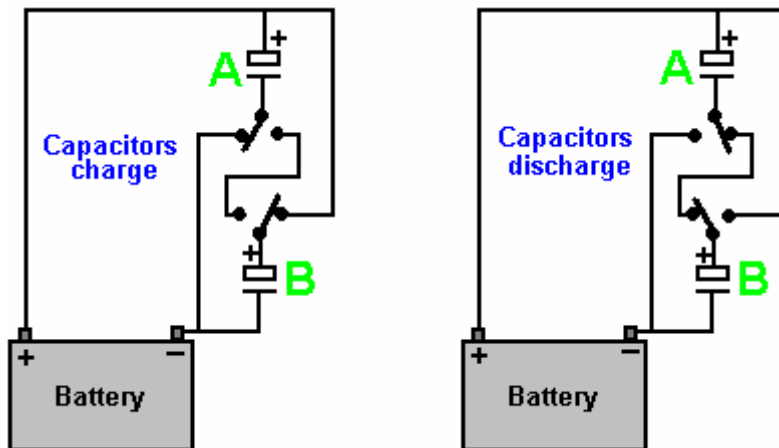

Here, when the switches are in one position, both the capacitors at A and B charge up to the full battery voltage. Then when the 2-pole changeover (break-before-make) switch is moved to its other position, the capacitors are

connected together, suddenly applying twice the battery voltage to the battery terminals. This circuit principle was suggested by John Bedini on the Bill Jenkins radio show, but it does not have the voltage amplification advantage of a multi-filar choke in the way that the Lawton, Bedini pulse-charging and Boyce circuits have.

The effects caused by pulsing can also pull in excess energy from the gravity field. Mr. Lawrence Tseung has developed a theory which explains this. This theory can't be dismissed as "crackpot" as Mr. Tseung and his colleagues have developed very powerful engines based on this theory, engines powerful enough to power a car.

Mr. Tseung observes that gravitational power is 'lead-out' of a device when an impulse is applied to the device. One of the components very much suited to this energy gain is a flywheel, where the excess energy drawn out during every pulse applied to the flywheel is $2mgr$ where m is the mass (weight) of the flywheel, g is the gravitational constant, and r is the radius of the flywheel. This equation assumes that the flywheel mass is all at the rim, so in practice, the additional energy gained will not be quite that high, although the construction of the flywheel should aim for a maximum rim weight. No energy gain is produced when the flywheel is rotated evenly at a constant rate. The energy gain is at the moment when a driving pulse is applied to the flywheel.

Recently, Mr. Chas Campbell of Australia demonstrated electrical power gain with a flywheel system which he developed:

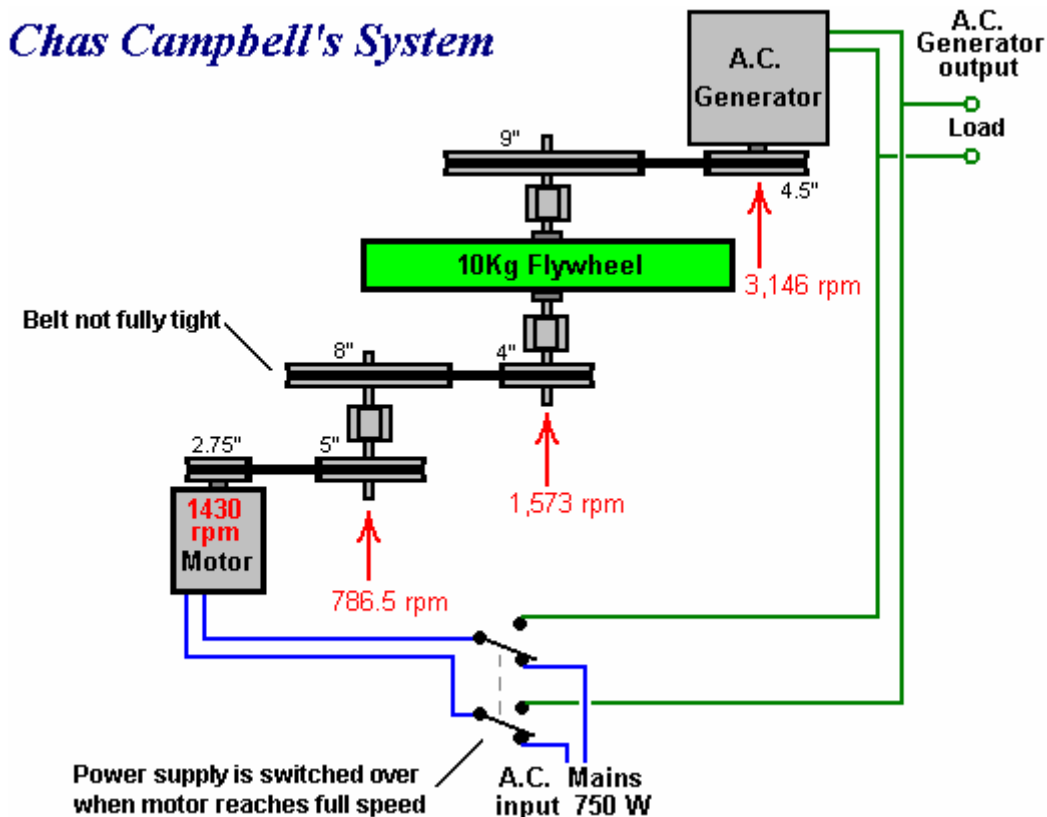

But what this diagram does not show, is that a couple of the drive belts are left with excessive slack. This causes a rapid series of jerks in the drive between the mains motor and the flywheel. These occur so rapidly that they do not appear noticeable when looking at the system operating. However, this stream of very short pulses in the drive chain, generates a considerable amount of excess energy drawn from the gravitational field. Chas has now confirmed the excess energy by getting the flywheel up to speed and then switching the drive motor input to the output generator. The result is a self-powered system capable of running extra loads.

This is not an isolated case. On page 19 of the book "Free Energy Generation - Circuits and Schematics" John Bedini shows a diagram of a motor/generator which he has had running for three years continuously while keeping its own battery fully charged. At John's web site <http://www.icehouse.net/john34/bedinibearden.html> about two thirds of the way down the page, there is a black and white picture of a very large construction version of this motor. The important thing about this motor is that it is being driven by electrical pulses which apply a continuous stream of short drive pulses to the flywheel. This extracts a steady stream of continuous energy drawn out from the gravitational field, enough to charge the driving battery and keep the motor running. The large version built by Jim Watson had an excess power output of many kilowatts, due to the very large size and weight of its flywheel. It is also likely that Joseph Newman's motor gains additional energy from its large physical weight of some 90 kilograms driven by a continuous stream of pulses. Any wheel or rotor assembly which is driven with a series of mechanical

pulses, should benefit from having a serious flywheel attached to the shaft, or alternatively, the outer edge of the rotor. Engineers consider that effect of a flywheel on an irregular system is to iron out the irregularities in the rotation. That is correct as a flywheel does do that, but Lawrence Tseung's gravity "lead-out" theory indicates that those irregular pulses also add energy to the system.

The Robert Adams motor springs to mind as a rotating disc driven by a series of pulses, whether those pulses are attracting or repulsing. The adjustment of the motor can be either way as described in the D2.pdf document, but the rotor rotates because it is receiving mechanical pulses from the magnetic gear of the motor. Lawrence Tseung's theory suggests that if the rotor of the Adams motor were given a heavy outer ring, then the power gain would be improved due to additional gravitic energy being extracted as free-energy added to the device.

Paul Baumann's 'Thestatika' Machine. This machine works beautifully. It is self-powered and produces in excess of 2 kW of electrical output continuously. It has two electrostatic discs which are rotated by motor to produce a continuous current. It works best in dry atmospheric conditions. The snag is, it was developed by the late Paul Baumann who was part of a Swiss commune which is not willing to explain its operation.

Paul E Potter has attempted to deduce the operating principles and has published interesting information at the <http://website.lineone.net/~aarekhu/> website. His picture from that location is:

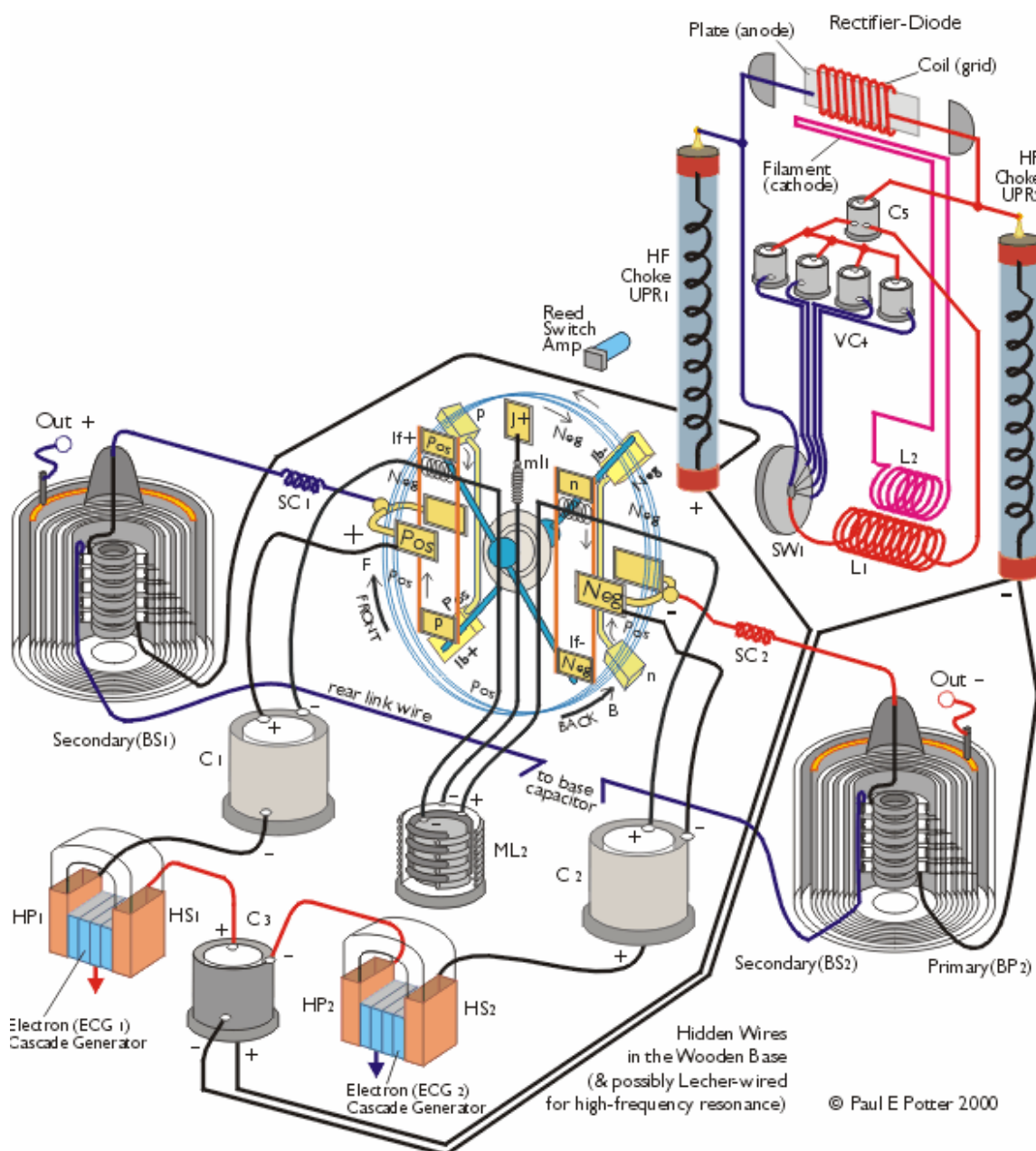

One very interesting fact which has been reported by the Swiss group is that if a series of copper, aluminium and Perspex sheets are placed in a magnetic field, they generate a high voltage. This is worth investigating. It is not clear if the magnetic field should be constant or oscillating. The sequence of plates is said to be: cpacpacpacpa ("c" being copper, "p" being 'Perspex' (acrylic or 'Plexiglas') and "a" being aluminium). The following set-up might be worth investigating:

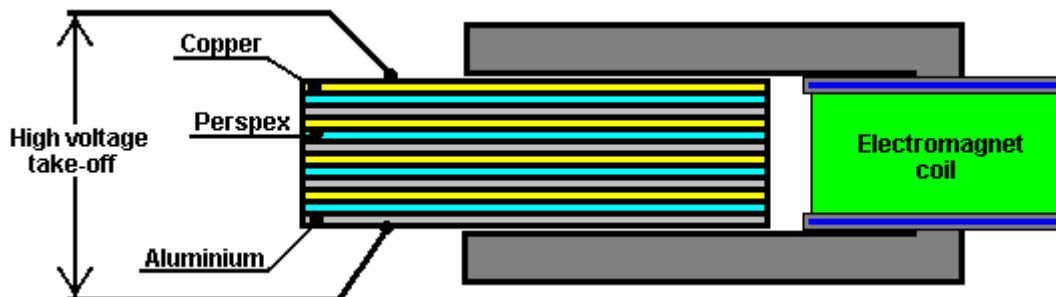

Paul Baumann's device may operate by creating a series of very short, high-power electrical discharges in the conductors passing through the centre of the two cylinders. These cylinders are effectively the same as Ed Gray's discharge tube, both having metal shells around the pulsed conductor. The shells pick up the waves of Radiant Energy created by the electrical pulses and feed that energy to the workload. It would be easy to assume that Paul used a motor-driven version of a Wimshurst machine to pick up 'static' energy to create the sparks, as shown below but reports from the commune state that the static electricity discs rotate on their own with no motor being use to drive them. There is no obvious way to explain how that would happen, but reliable reports indicate that that is exactly what happens after the device is set in motion by hand.

Shorn of all of its frills, the operation of Paul's machine might be as shown here:

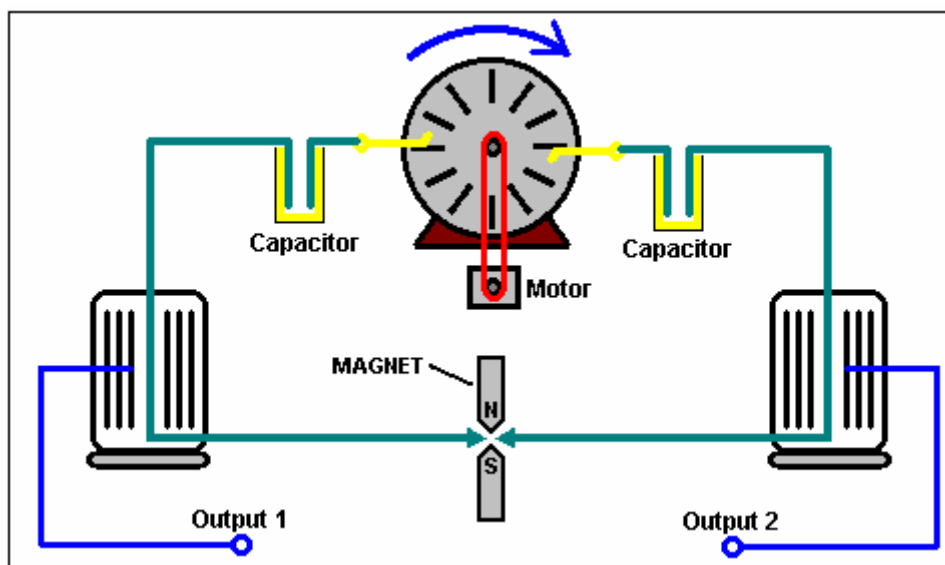

The operation might be fairly simple. The drive motor is powered by part of one of the outputs, so no input power is required. The capacitors charge up quickly and cause a train of sparks. These sparks get cut off very sharply by a strong magnetic field provided by a strong permanent magnet (or electromagnet) as recommended by Nikola Tesla. These very sharp, short, electrical bursts generate a shock wave of Radiant Energy which surges outwards through the metal cylinders surrounding the cabling to the spark gap. These cylinders are normally made out of copper sheet drilled with a matrix of holes and they pick up some of the radiant energy which forms the output of the device. The McGraw-Hill book "Homemade Lightning" by R.A. Ford (ISBN 0-07-021528-6) gives full details of Wimshurst machines and plans for constructing your own, improved version. Ready-built Wimshurst machines are available from the web site: <http://scientificsonline.com/product.asp?pn=3070070&bhcd2=1154180654>

Wire Sizes:

The wire sizes specified for use in some designs are American Wire Gauge so a comparison table showing the UK Standard Wire Gauge and the American Wire Gauge is given here:

AWG	Dia mm	Area mm ²	SWG	Dia mm	Area mm ²	Max Amps	Ohms / metre	Max Hz
1	7.35	42.40	2	7.01	38.60	119		325
2	6.54	33.60	3	6.40	32.18	94		410
3	5.88	27.15	4	5.89	27.27	75		500
4	5.19	21.20	6	4.88	18.68	60		650
5	4.62	16.80	7	4.47	15.70	47		810
6	4.11	13.30	8	4.06	12.97	37		1,100
7	3.67	10.60	9	3.66	10.51	30		1,300
8	3.26	8.35	10	3.25	8.30	24		1,650
9	2.91	6.62	11	2.95	6.82	19		2,050
10	2.59	5.27	12	2.64	5.48	15	0.0042	2,600
11	2.30	4.15	13	2.34	4.29	12	0.0053	3,200
12	2.05	3.31	14	2.03	3.24	9.3	0.0067	4,150
13	1.83	2.63	15	1.83	2.63	7.4	0.0085	5,300
14	1.63	2.08	16	1.63	2.08	5.9	0.0107	6,700
15	1.45	1.65	17	1.42	1.59	4.7	0.0135	8,250
16	1.29	1.31	18	1.219	1.17	3.7	0.0170	11 kHz
17	1.15	1.04				2.9	0.0214	13 kHz
18	1.024	0.823	19	1.016	0.811	2.3	0.027	17 kHz
19	0.912	0.653	20	0.914	0.657	1.8	0.034	21 kHz
20	0.812	0.519	21	0.813	0.519	1.5	0.043	27 kHz
21	0.723	0.412	22	0.711	0.397	1.2	0.054	33 kHz
22	0.644	0.325	23	0.610	0.292	0.92	0.069	42 kHz
23	0.573	0.259	24	0.559	0.245	0.729	0.086	53 kHz
24	0.511	0.205	25	0.508	0.203	0.577	0.109	68 kHz
25	0.455	0.163	26	0.457	0.164	0.457	0.137	85 kHz
26	0.405	0.128	27	0.417	0.136	0.361	0.174	107 kHz
27	0.361	0.102	28	0.376	0.111	0.288	0.218	130 kHz
28	0.321	0.0804	30	0.315	0.0779	0.226	0.276	170 kHz
29	0.286	0.0646	32	0.274	0.0591	0.182	0.344	210 kHz
30	0.255	0.0503	33	0.254	0.0506	0.142	0.439	270 kHz
31	0.226	0.0401	34	0.234	0.0428	0.113	0.554	340 kHz
32	0.203	0.0324	36	0.193	0.0293	0.091	0.685	430 kHz
33	0.180	0.0255	37	0.173	0.0234	0.072	0.870	540 kHz
34	0.160	0.0201	38	0.152	0.0182	0.056	1.105	690 kHz
35	0.142	0.0159	39	0.132	0.0137	0.044	1.398	870 kHz

Harold Aspden: Scientists freely acknowledge that more than 80% of the matter and energy in the universe is “dark matter” and “dark energy” where “dark” only means that we cannot readily see that form of matter and energy. The highly respected Harold Aspden has been awarded a patent for a system to collect this energy directly. The patent, which is one of several similar patents included in this set of documents, is reproduced here:

ELECTRICAL POWER GENERATING APPARATUS

Abstract

An electric generating device includes two capacitors **1** and **2**, each having a pair of concentric electrodes and in-series connection to inductors **3** and **4**. Each capacitor has an electrode connected to a high voltage DC source **5** and another connected to a low-voltage or earth terminal **6**. An AC Power output may be produced from terminals between each capacitor and inductor or from a transformer where the inductor is the primary winding. Electricity production may be sustained by drawing energy from the vacuum medium surrounding the electrodes.

Field of the Invention

This invention relates to a new and non-conventional means for the generation of electrical power. The energy source is the quantum underworld of space, the aether medium of the vacuum state, long recognised for its ability to allow the storage of electric field energy by reacting as its intrinsic charge is displaced, a process understood by physicists by reference to the research findings of Clerk Maxwell.

Background of the Invention

The current state of the art of electrical power generation does not recognise the possibility of ultimately tapping energy from the aether. Physics is taught on the basis that energy cannot be created or destroyed, inasmuch as it is conserved in all physical processes, though it can be degraded in its usefulness, as by burning of hydrocarbons and conversion into heat which dissipates as by radiation into outer space. The aether as a source or as an absorber of energy is not deemed to serve any specific role in the physics of energy deployment, it having been dismissed from consideration by invoking the notion of 'field energy' without admitting the specific physical reality of something in space that accounts for the properties involved.

Theoretical physicists have, however come to suspect that space devoid of matter is nevertheless a seething sea of activity subject to sporadic energy fluctuations which can create electron-positron pairs that exist momentarily before decaying back into their quantum underworld. Yet those same physicists deny all possibility that this energy resource of space itself can be exploited to provide useful power on a scale large enough to rival the role played by atomic power plants and fossil fuel generating installations.

Curiously, they do subscribe to the belief that one day they may be able to generate power on a viable commercial scale from fusion reactors by processes replicating what they believe sustains the Sun's heat output as hydrogen is transmuted into different atomic forms. In contrast with this rather elusive objective, it having proved beyond reach even after half a century of effort, this invention is based on success in generating power by replicating, not the Sun's onward energy decay, but rather a process akin to that by which the Sun itself was created from energy drawn from the enveloping aether medium.

The invention to be described below has emerged from an in depth theoretical investigation into the properties of the aether and quite independently of any of the well known claims of published record which feature at the fringe of mainstream scientific literature. A recent and very well-presented account of what amounts to a century of relevant energy history is the book 'The Search for Free Energy' by Keith Tutt, published in 2001 by Simon Schuster (ISBN 0-684-86660-9). Here in this book is a comprehensive background of information concerning the energy devices of several researchers but the references to Nikola Tesla and T. Henry Moray are particularly pertinent to the subject of this invention and, though imposing a limitation on what can be legitimately claimed by this patent application, they serve also as a basis for a very important lesson to those engaging in this field of invention.

The lesson is that it is not sufficient to build and demonstrate something that works, if you do not fully understand why what you have devised actually does work. This is especially the case here where one is claiming a source of energy hitherto unknown. The invention to be described below will, in its broadest sense, appear to be quite similar to what T. Henry Moray is said to have demonstrated in showing that substantial electrical power could seemingly be drawn from the aether using a simple wire antenna strung between two poles.

However, as will be seen, the antenna is not needed and the reason is that the energy source is not the radiant

emission by some process involving radio wave propagation through the anther, but rather what can best be described as a phase-lock that couples the apparatus with the quantised motion of electric aether charge. There is a technique, to be described below, by which it is possible to exploit this phase-lock condition by setting up an energy oscillation involving an apparatus component and its enveloping aether, the result being that energy in an immediately useful electrical form is imported into the apparatus from that aether.

Brief Description of the Invention

According; to one aspect of the invention, an electric power delivery circuit comprises two capacitors, each having a pair of electrodes formed by a pair of metal cylinders having concentric axes, each capacitor having an associated inductor series-connected to it to form a capacitor-inductor unit, DC voltage excitation means connected to a parallel combination of the two capacitor-inductor units, whereby to apply between corresponding electrodes of the capacitors a DC bias voltage which primes them with electric charge, and power output terminals. one at each point of connection between a capacitor and its associated inductor, whereby to provide for an AC power output owing to oscillations of electric charge between the two capacitors at the resonant frequency of the capacitor-inductor units.

According to another aspect of the invention, an electric power-delivery circuit comprises two capacitors, each having a pair of electrodes formed by a pair of metal cylinders having concentric axes, each capacitor having an associated inductor series-connected to it to form a capacitor-inductor unit, DC voltage excitation means connected to a parallel combination of the two capacitor-inductor units, whereby to apply between corresponding electrodes of the capacitors, a DC bias voltage which primes them with electric charge, each inductor being the primary winding of an electrical transformer, the secondary winding of which serves to provide an AC power output owing to oscillations of electric charge between the two capacitors at the resonant frequency of the capacitor-inductor units.

According to a feature of the invention the capacitors have no intervening solid or liquid dielectric medium separating their concentric electrodes.

According to another feature of the invention, two inductors are coupled electromagnetically by having a common ferrite core and their primary windings are connected to their associated capacitors in the polarity configuration which assures that, in their mutually resonant state, electric charge is exchanged between the two capacitors.

According to yet another feature of the invention, the central axes of both cylindrical electrode capacitors are mutually parallel.

According to a further feature of the invention, an electrical power delivery system comprises a plurality of these electric power delivery circuits, where the central axes have different angular orientations as between the different circuits.

According to a still further feature of the invention, in such a power delivery system, the difference in angular orientation of the central axes is at least 60° .

Brief Description of the Drawings

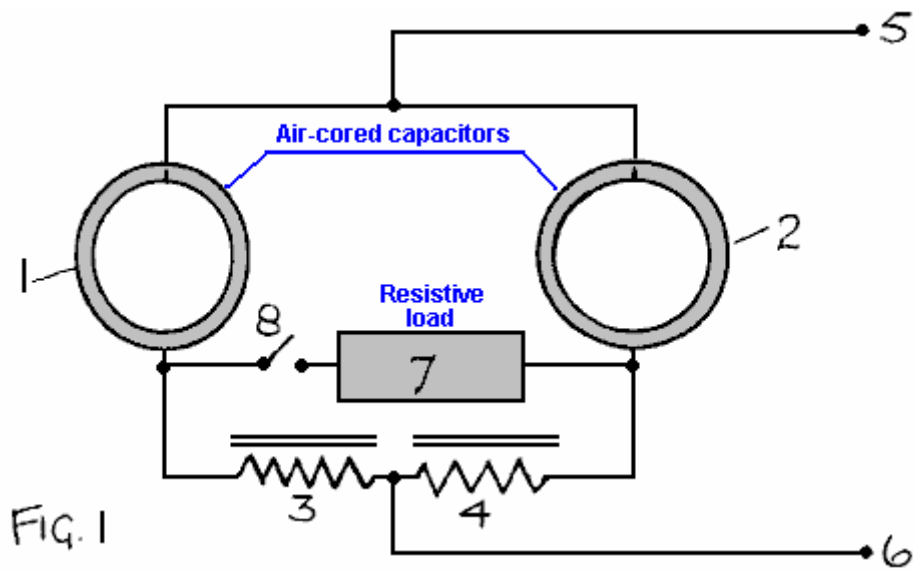

Fig.1 shows an electrical power generating circuit incorporating two concentric cylindrical capacitors having central axes which are parallel.

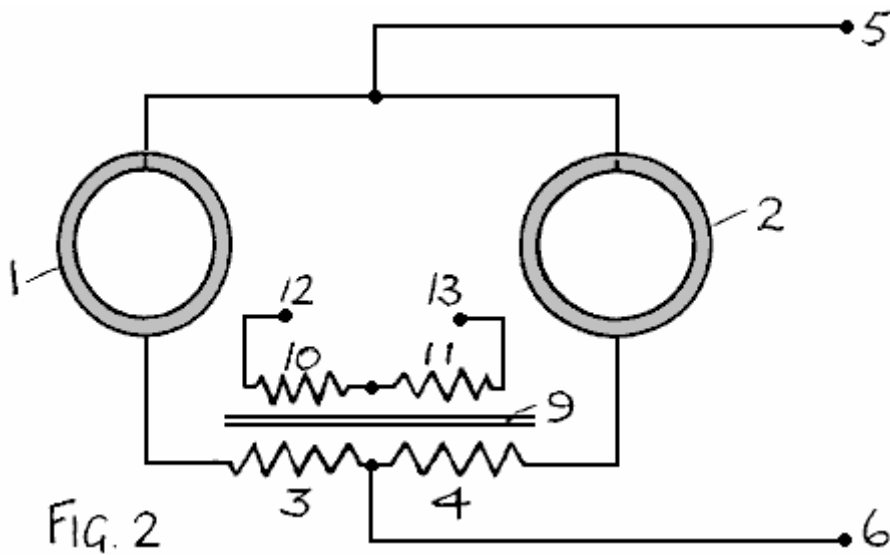

Fig.2 shows a modified version of the circuit of **Fig.1** with a transformer system providing the inductors and an output winding.

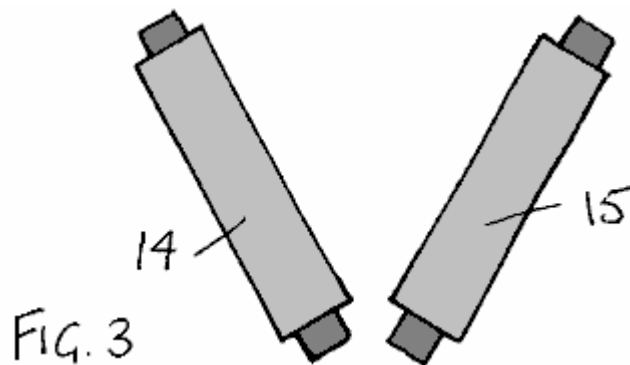

Fig.3 illustrates a mutually inclined capacitor system comprising two pairs of concentric cylindrical capacitors.

Detailed Description of the Invention

The invention draws energy from the aether. To understand why the invention works, one needs to understand the process by which the aether stores energy when an electric field is set up across the dielectric separating two capacitor plates. Moreover, one needs to understand the means by which the aether determines the quantum of action, specifically in the form of the Bohr magneton and the unit of angular momentum linked to Planck's constant.

It is not sufficient to imagine that electric charge in the aether is displaced from a rest position in a background continuum of opposite charge polarity to which it is attracted by a restoring force. Indeed, one must consider such action to be superimposed on a system of charge which has an underlying jitter motion, a quantum theory theme associated with the German physicist Heisenberg (Zitter-bewegung, which has the dictionary meaning 'Circular fluctuation movement, of spin'). When these two factors are combined, and the constraint added of there being a phase-lock which keeps that jitter motion in synchronism as between the charges, one finds that the physical theory involved has some very interesting consequences.

One of these consequences is that a spherical or cylindrical volume of aether, if spinning bodily about a central axis, will acquire a magnetic moment and set up an electric field inside that sphere or cylinder that is directed radially with respect to the spin axis. A summary analysis is presented in the Appendix to this specification, being, in part a quotation from pages 31-33 of a booklet entitled 'The Theory of Gravitation' which the Applicant of this invention, Dr. Harold Aspden, authored in 1959 and duly published early in 1960.

The induction of electric charge by 'aether spin' was there shown to give a physical basis, both qualitative and quantitative, for the geomagnetic moment, the property of body Earth of setting up a magnetic field which created magnetic North and South poles at latitudes offset from the geographic poles, with the geomagnetic polar axis precessing slowly around the Earth's spin axis at a rate of several hundred years per revolution. By identifying its source as a rotation of a sphere of aether coextensive with body Earth, a volume of aether relative to which the Earth could have a component of motion even though the aether spin frequency is equal to that of the Earth, this axial tilt of some 17 degrees has a physical explanation. However, that aspect of the aether's role was not seen at the time as offering anything of promise technologically. The physics involved is nevertheless very relevant and directly pertinent to the experiments on which this invention is based, the findings of which would otherwise be quite baffling scientifically.

The applicant has, over the 40 or so years since the theory was first published, given a great deal of consideration to the theoretical implication that, just as aether spin can set up electric charge displacement inside coextensive matter, so the setting up of an electric field directed radially with respect to an s axis can induce aether spin about that axis and with it develop angular momentum. Indeed, in the author's onward publications on this subject, as, for example, 'Physics Unified' published in 1980 by Sabbiton Publications, P.O. Box 35, Southampton, England (ISBN 0 85056 0098), it is shown how the onset of the force of gravitation when a disordered aether consolidated into an orderly structured form caused protons to accrete more rapidly than electrons, owing to their higher mutual rate of gravitational acceleration. This created stars with all initial positive charge and the associated aether spin resulted in the stars acquiring their spin states and shedding matter which consolidated into planets which share the angular momentum so generated. The aether with its property of spin as related by its electric charge density according to the formula presented in the Appendix is therefore the key factor if we attempt to account for the creation of the stars which populate our universe.

That same formula, however, is equally valid if applied to the circumstance where a radial electric field is set up between the concentric cylindrical electrodes of a capacitor formed around a hollow dielectric cylinder. It tells us how fast the aether within that dielectric will spin. The related theoretical analysis shows that the quantum phase-lock feature of the aether imports from the external aether world an amount of energy equal to that supplied in setting up aether charge displacement, this imported energy being the dynamic energy corresponding; to the acquired aether angular momentum. Guided by the argument concerning stellar creation one can see that this aether angular momentum can be transferred to matter and this process also has its energy transfer implications.

However, one can wonder what happens if, after setting up a radial electric field in that capacitor having concentric electrodes, the applied voltage is reduced, thereby withdrawing electric field energy from the capacitor. The imported energy present in kinetic energy form as a cylindrical shell of aether spins about the central axis of the capacitor will tend to sustain electric charge displacement. To conserve energy, since the aether phase-lock cannot force the expulsion of energy by obliging the enveloping aether universe to keep in step, this energy can only be shed by augmenting that released electrostatically. In other words, the net result is that an up and down fluctuation of the electric charge condition of the capacitor must give rise to an electric energy output that is, for the

lowest dielectric constant (the permittivity of the vacuum), double the input in each cycle of change. One can then envisage an oscillation escalating in energy content powered almost wholly by aether input before one taps into that source of power to draw off energy at a rate consistent with stable operation.

This is, of course, a bewildering prediction that no physicist could imagine as being at all possible and yet, given the relevance of the theoretical argument involved, as applied to the phenomenon of geomagnetism and stellar creation, which are supported by strong evidence in that book 'Physics Unified', once such a notion is conceived it surely has to be put to the test by experiment. This then, after decades of effort before this realisation has dawned, is the basis on which the Applicant has only now come to appreciate the amazing technological possibilities that lie before us and is asserting by this patent specification that energy can in fact be tapped from the aether on a commercially viable scale.

Given that aether theory indicates that the special form of capacitor described above will, if subject to an oscillatory charge condition, generate an excess of energy, a question to consider is why such a phenomenon has not manifested itself in bench-type experiments performed in numerous electrical laboratories over the past one hundred years. Ostensibly the implication is that the capacitor will exhibit a negative resistance if used with an inductor as a component in what would become a self-resonating circuit. The answer to this may be that if such a phenomenon has occurred it has passed unnoticed or been regarded as spurious or noise-related, being something connected with radio interference etc. Alternatively, and as a function of the size and scale of the apparatus, the effect may have lacked an exciting trigger needed to overcome an energy threshold set by such factors as circuit contact resistance or contact potentials as well as the basic resistance of the inductors which, with the capacitors, form the resonant circuit.

Note that, even for a capacitor of quite large physical dimensions, having regard to its accommodation on top of a laboratory bench, the actual capacitance is necessarily quite small. being of the order of a billionth of a farad. This means that a capacitor charge fluctuation of the order of a volt would only imply energy fluctuations that are of the order of a billionth of a joule per cycle. The situation is quite different if perchance a DC bias voltage of, say, 5,000 volts is applied to the capacitor. Then a small superimposed voltage fluctuation makes the related energy fluctuations very much larger with much greater prospect of an escalating self-resonance being triggered.

With this in mind the applicant perceived a possible prior art link with the experimental claims reported by Dr. Moray who, in 1929 is said (see pages 46-50 of the above-referenced recently-published book by Keith Tutt) to have powered six 100 watt light bulbs plus a standard 575 watt electric flat iron, merely by providing an earth connection and coupling an input lead to an overhead wire antenna. The apparatus involved had no other source of input power but included a special arrangement of capacitors and presumably some kind of high frequency inductor/transformer unit.

In spite of the attention given to the Moray demonstrations, it seems that the secrets involved in the design and construction of the apparatus remain unknown and so cannot feature in the prior art of published record. Nor, indeed, can the anecdotal evidence of Moray's efforts serve to show that the subject invention has been put to prior use. The technology as to how to replicate the Moray device, always assuming it did perform as claimed, has therefore to be rediscovered and, indeed, given that there is reference to his detectors incorporating some special substance which was referred to as 'Swedish stone', possibly the dielectric he used in his capacitor construction, there is a considerable mystery to unravel. More to the point, however, one is led to believe that Moray was implying that the energy he was tapping was radiant energy drawn from the aether, with that antenna featuring prominently because, without it being connected, the energy output fell to zero. However, as he surely may well himself have known, one just cannot draw power on such a scale from a simple overhead wire strung between two poles and so, without know how, he would have suspected that the energy inflow was coming into his capacitors via the action of that mystery substance he called 'Swedish Stone'.

The applicant here suggests that, based on an insight into the quantum workings of the aether medium as outlined above, the curious discovery demonstrated decades ago by Dr. Moray may have been attributable to setting up an oscillation in a resonant circuit including, a concentric cylindrical electrode capacitor which had a voltage bias of the order of a thousand and more volts fed from a connection to that overhead antenna but drawing no significant current from that antenna other than enough to prime his capacitor with charge and stimulate a high frequency fluctuation which could initiate an escalating circuit oscillation tapping aether energy from the aether spin induced in the capacitor dielectric.

This is speculation, but it is sufficient to justify the Applicant's interest in constructing a capacitor and seeking to verify the assumptions just made. Notwithstanding, the reference allude to Dr. Moray and the note below concerning Nikola Tesla, what it leads to is new invention by virtue of full disclosure of details of operation and manufacture of something hitherto unknown, the actual means by which to harness a source of energy latent in the aether medium and deemed by those familiar with state of the art knowledge to be beyond man's reach.

Furthermore, there are supplementary inventive features of a special nature because of the way the subject invention exchanges energy between two capacitors and also because the optimisation of aether power output from the capacitors is found to be a function of the orientation of the capacitor axes relative to the cosmic background owing to the Earth's rotation.

It seems here appropriate to mention something described by Nikola Tesla in his U.S. Patent No. 685,958. This was filed on 21 March 1901 and granted on 5 November 1901. It was entitled: 'Apparatus for the Utilisation of Radiant Energy'. By installing two metal plates, one high above the ground and the other at ground level, with wires connecting the plates to separate electrodes of a capacitor, it was stated that the capacitor became charged to a very high potential, the energy input being that radiated to Earth from outer space. This may well have motivated the efforts of T. Henry Moray but, so far as this Applicant's invention is concerned, no such input from overhead components is necessary as a quite different energy source is at work, namely the zero-point vacuum energy activity of our quantum underworld.

Referring now to **Fig.1**, two capacitors **1, 2** formed by concentric cylindrical metal electrodes and having their central axes parallel, form part of a resonant circuit combination by each being series-connected to an inductor **3, 4** having a ferrite core. Their inner electrodes are connected to a high-voltage DC source **5** and their outer electrodes are separately connected through their corresponding inductors to a low-voltage or earth terminal **6**. A resistive load device **7** is connected via switch **8** between the junction points of the capacitors and inductors.

In operation, owing to spurious electrical signals induced in the inductors, or to an imposed electrical stimulus provided by means not shown, the priming electric charge of the two capacitors will develop oscillations as charge is exchanged between the two capacitors. There is energy inflow owing to the quantum coupling of electric charge displaced between the concentric electrodes of each capacitor and the quantum activity of the underworld of the enveloping aether. This affords an electrical energy output which is supplied upon closure of switch **8**.

Referring to **Fig.2**, the inductors **3, 4** are shown to have a common ferrite core **9** and to have secondary windings **10,11**, which, by transformer action, can supply electrical power output between terminals **12** and **13**.

The apparatus of **Fig.1** and **Fig.2** will, when viewed in side elevation, appear as having a capacitor form with an outer cylindrical electrode within which there is a slightly elongated inner cylindrical electrode, to facilitate the high-voltage connection to that inner electrode. **Fig.3** shows, in very simple diagrammatic form, two such arrangements **14, 15**, with the central axes of the two pairs of capacitors mutually inclined. There may, however, be three or more such pairs of capacitors, each pair constituting a circuit such as is depicted in **Fig.1** or **Fig.2**.

The reason for configuring multiple capacitor systems, each with its own power output, in a combined manner with the outputs merged to supply an overall energy producing system is that the aether energy output of each capacitor unit is a function of axis orientation. This is because the quantum activity of the aether has its own preferred axis and, as the Earth rotates there is variation of the relative axial orientation in a daily cycle. Also, one needs to cater for systems applying, this invention in a mobile application, which also implies change of orientation and by having; the mutually inclined capacitor axis configurations one can be assured that the potential power output avoids the null situation that can occur if the capacitor axes of a stand-alone unit of **Fig.1** or **Fig.2** were to be at right angles to the aether quantum spin axis.

The capacitor electrodes can be of thin metal sheet foam and so of light weight and preferably are not spaced apart by any dielectric medium, whether liquid or solid. They need to be held apart by a simple insulating frame structure. The reason is, that the only dielectric medium that is operative in the functioning of the invention is the vacuum medium and to have a normal dielectric present implies more capacitance and so extra current oscillation without extra energy gain per cycle of oscillation. The key factor assuring operation is the need for circuit resistance to be low compared with capacitance that is solely attributable to the vacuum medium combined with the high voltage priming which greatly enhances the power output to weight factor.

The two capacitors of a pair are preferably of identical capacitance and structure, as are the inductors, so that the oscillation period of the two resonant sectors of the circuit is the same. The common ferrite core feature of the **Fig.2** configuration assists in this role.

The apparatus will normally be designed to operate at a capacitor frequency of the order of 100 KHz or more, and a voltage of 10,000 V or higher, and so the transformer output of **Fig.2** will be preferable with voltage duly adjusted to suit the application. The high frequency AC so produced can then be converted as needed by using the appropriate technology of known form.

Appendix

Extract from pp. 30-31 of 'The Theory of Gravitation', 1960 printed publication by the Applicant. Note that the earlier pages explained that the aether comprises a system of electric particles in a cubic crystal-like distribution set in a uniform background continuum of opposite charge polarity, the particle system and the continuum both sharing a common circular orbital motion of radius r and the relative velocity between the particles and continuum being the speed of light.

The Effect of Aether Rotation

Consider what happens when a large volume of the aether is rotating bodily. The continuum and particle system rotate together. There will be no resultant magnetic moment unless the particle distribution is disturbed. An evident disturbance is the centrifugal effect arising from aether rotation, but for the angular velocities of magnitude found in the solar system this effect is of negligible consequence. A much more important effect arises from the synchronising interaction between particles in the rotating volume. This requires that the particles shall move about their neutral points at the same angular velocity. Thus if a particle is to have a velocity component V directed in the plane of its orbit, whilst retaining a mean velocity $C/2$, its speed along its orbit must be of the form $C/2 + V \cos P$, where P is the angle subtended by a line joining the particle and the centre of its orbit relative to a fixed reference datum in the inertial frame. To satisfy the above requirement the centre of the orbit cannot be the neutral point. Evidently the particle is distant from this neutral point by $r + (2Vr/C) \cos P$. As V is much less than C the effect of this is that the particle is moving around a circular orbit whose centre has been displaced a distance $2Vr/C$ perpendicular to V in the plane of the orbit. If V is much less than $\omega x \cos A$, where ω is the angular velocity at which the aether rotates, x is the distance of the aether particle from the axis of rotation, and A is the angle of tilt of the axis to the common axial direction of the aether particle system, this displacement distance is $2(\omega x r / C) \cos A$. Consider a disc-like section of the rotating aether of radius x and unit thickness. Then, the effective charge displacement arising from the effective physical displacement of the particles is $2 \pi x s (2 \omega x r / C) \cos A$. The disc has acquired a uniform charge density of $4(\omega r s / C) \cos A$ esu/cc. The polarity of this charge depends upon the direction of rotation of the aether.

When evaluated from the aether data already presented, the charge density is found to be: $4.781 \omega \cos A$ esu/cc. This charge density represents a charge component which rotates with the aether.

Calculation of the Geomagnetic Moment

For Earth, ω is 7.26×10^{-5} rad/sec and A is 23.5° . Thus the Earth's charge density is, from the above expression, 0.000319 esu/cc. The rotation of this charge gives rise to a magnetic moment of:

$(0.000319)(4 \pi / 15) \omega R^5 / C$ where R is here the radius of the Earth's aether.

If R is greater than the Earth's radius (6.378×10^8 cm) by a small factor k , the Earth's theoretical magnetic moment becomes $(1 + 5k)6.8 \times 10^{25}$ emu. This may be compared with the measured value of the Earth's magnetic moment of 8.06×10^{25} emu.

An upper limit of 0.035 is imposed on k suggesting the Earth's aether terminates at a mean height of about 140 miles above the Earth's surface. This suggests that the ionosphere may be a phenomenon arising at the aether boundary.

Claims

1 An electric power delivery circuit comprising two capacitors each having a pair of electrodes formed by a pair of metal cylinders having concentric axes, each capacitor having an associated inductor series-connected to it to form a capacitor-inductor unit, DC voltage excitation means connected to a parallel combination of the two capacitor-inductor units, whereby to apply between corresponding electrodes of the capacitors, a DC bias voltage which primes them with electric charge, and power output terminals, one at each point of connection between a capacitor and its associated inductor, whereby to provide for an AC power output owing to oscillations of electric charge between the two capacitors at the resonant frequency of the capacitor-inductor units.

2 An electric power delivery circuit comprising two capacitors, each having a pair of electrodes formed by a pair of metal cylinders having concentric axes, each capacitor having an associated inductor series-connected to it to form a capacitor-inductor unit, DC voltage excitation means connected to a parallel combination of the two capacitor-

inductor units, whereby to apply between corresponding electrodes of the capacitors a DC bias voltage which primes them with electric charge, each inductor being the primary winding of an electrical transformer, the secondary winding of which, serves to provide an AC power output owing to oscillations of electric charge between the two capacitors at the resonant frequency of the capacitor-inductor units.

- 3 An electric power delivery circuit according to Claim 1 or 2, wherein the capacitors have no intervening solid dielectric medium separating their concentric electrodes.
- 4 An electric power delivery circuit according; to Claim 1 or 2, wherein the capacitors have no intervening liquid dielectric medium separating their concentric electrodes.
- 5 An electric power delivery circuit according to Claim 1 or 2, wherein the two inductors are coupled electromagnetically by having a common ferrite core and their primary windings are connected to their associated capacitors in the polarity configuration which assures that, in their mutually resonant state, electric charge is exchanged between the two capacitors.
- 6 An electric power delivery circuit according to Claim 1 or 2, wherein the central axes of both cylindrical electrode capacitors are mutually parallel.
- 7 An electric power delivery system comprising a plurality of electric power delivery circuits according to Claim 6, wherein the central axes have different angular orientations as between the different circuits.
- 8 An electric power delivery system according to Claim 7, wherein the difference in angular orientation of the central axes is at least 60° .

Comment by Dr. Aspden on 19th March 2006:

OUR ENERGY FUTURE

A Message of Vital Importance

The website www.energyscience.org.uk presents a deliberately concise summary account of something of vital importance to the future of mankind. The world needs a new source of energy, one that is not an exhaustible commodity subject to powerplay as between nations. Yes, one can dream and then awake to say this is impossible, but I urge those with the necessary skills to heed what I have to say in my three messages below.

First, however, let me introduce myself. My name is Dr. Harold Aspden. I am retired and elderly but have had a lifelong scientific interest in fundamental physics relevant to the energy theme. My 6-year university education in U.K. was at Manchester University and Cambridge University (Trinity College). My 33-year working career in U.K. comprised 9 years with English Electric and 24 years with IBM. Though having high technical qualifications (see below), being interested in the specialised field of protecting inventions pertaining to electrical engineering, I became a Chartered Patent Agent and later a European Patent Attorney. My last 19 years with IBM were spent as Director of IBM's European Patent Operations. This was followed, in my early retirement, by 9 years as a Visiting Senior Research Fellow at Southampton University and thereafter my scientific interest has been a private pursuit evidenced by my writings as on this and my related websites. My formal qualifications are: B.Sc., Ph.D., C.Eng., F.I.E.E., F.I.Mech.E., C.Phys., M. Inst.P., C. Sci., Wh.Sc.

Message No. 1: Physicists have come to recognise that there exists a quantum underworld alive with energy and permeating all space. However, their related research aims merely at probing experimentally the spectrum of elementary particles that have a transient existence as a product of that energy activity. The reward they seek is recognition should new particles be discovered and, by their properties, reveal connections with other particles that help in formulating a new theory or verifying an existing theory. Sadly, they do not see that quantum underworld as a potential source of energy that we can harness. Nor have they understood how most of the energy shed in creating matter formed the elementary particle which bears the name proton and which, together with the electron, constitutes the hydrogen atom.

There is also a secret they have yet to fathom. It is the effect of creating a radial electric field centred on electrical charge around which that quantum underworld can develop a state of spin that causes it to shed energy. In the presence of a radial electric field set up by an electrically charge body, whatever constitutes that quantum underworld that permeates all space shares a motion like that of sequence dancers who keep in step with one

another as they move around the dance floor, a synchronous motion, which, in the presence of that radial electric field can only be held if a secondary motion develops around an axis centred in that radial field.

How else could the Sun spinning about its own axis have come into existence? Here we have gravity attracting hydrogen atoms and pulling them so closely together that ionisation occurs, meaning freeing some electrons from their proton bonding, and so, because the mass of a proton is very much greater than that of the electron, creating a Sun having a body that is positively charged sitting within an outer shell of negative electron charge. Two free protons experience a mutual rate of gravitational acceleration that is 1836 times that experienced by the interaction of two electrons. The body of the Sun, therefore, has a uniform mass density and a uniform positive charge density enclosed within a compensating negative charge at its surface. This is because gravitational compaction forces balance the expansion forces attributable to electrostatic repulsion. It further means the presence of a radial electric field within the body of the Sun and, in turn, owing to the effect of this field on the space medium of the quantum underworld, this induces a state of spin accompanied by release of energy from that medium to feed the kinetic energy of that spin.

In depth analysis of the physics involved, meaning the effect of the resulting radial electric field on that quantum underworld, then allows one to calculate the resulting rate of spin and thereby understand how the solar system was created.

So, if the reader is a physicist, here is the way forward and full guidance on this is to be found on my parallel website www.aspden.org or in a new book of mine entitled Creation - The Physical Truth, that will be published in the near future. However, if the reader is not a physicist but has the technological aptitudes of the university-trained electrical engineer then it is Message No. 2 below that warrants attention.

Message No. 2: If it were possible to generate electrical energy by tapping an omnipresent medium it is surely to be expected that the occasional natural phenomenon might already have hinted at this possibility. Consider, therefore, the thunderball, a glowing spherical object sometimes seen, especially following a lightning storm. It appears ethereal in the sense that it can move unimpeded through matter, yet remains an enigma, an unsolved mystery of record in the annals of science. Lightning strokes are high current discharges which, as electrical engineers well know, can develop a 'pinch effect' squeezing the electron-carried current into a filamentary flow within a cylindrical channel of positively charged air. That implies a radial electric field, a pulsating radial electrical field if the discharge surges, a sure recipe for something to happen that could form a miniature Sun, the thunderball. So when we look at a thunderball we are looking at a natural phenomenon that has drawn energy from that quantum underworld of space, energy which is then dissipated, but energy shed by a process we can surely harness, once we understand the physics involved.

Scientists lacking the necessary imagination do not seek to understand how the thunderball is created and so they seldom write about it. So here we have something to think about. It is Nature's message telling us: "Produce a radial electric field, one that pulsates, and you can develop a spin that taps energy from the quantum underworld of space." As engineers, however, we need to be practical and, if possible, we should avoid trying to replicate a phenomenon that involves powerful electric discharges, if there are better ways in which to proceed.

So now I come to my primary theme in this Message No. 2. It is a brief survey of a few of the claims of record that have declared a mysterious energy gain and have features which I see as relevant to what has been said above. In particular I draw attention to the research findings of four different pioneers in what has come to be termed 'The Search for Free Energy', this being the title of a really excellent book by Keith Tutt, published by Simon & Schuster in 2001. Three of these are described in considerable detail in that work. I now ask you to keep in mind my reference to a radial electric field as I mention each of them below and do realise that electrical structures of cylindrical form are a key feature.

Nikola Tesla is famous for his research concerning electromagnetic induction and high voltage solenoidal transformer apparatus (Tesla coils) and he is said to have demonstrated an automobile which derived its power by tapping energy from space. He did not disclose its design details and died leaving us with a mystery. Tesla coils comprise large solenoidal windings concentrically mounted and operate with high voltage pulsations between their cylindrical forms which must produce a pulsating radial electric field between those windings. So, although electromagnetic induction effects are the primary focus of attention, there is here scope for the electrical action described in Message No. 1 above. Tesla may well have stumbled experimentally upon a way of tapping energy from space, but without understanding the true underlying physical process.

Dr. Henry Moray, a pioneer of the 1920-1930 era, demonstrated something which merely needed a kind of antenna, a wire connected from tree tops to earth via electrical apparatus in the boot (trunk) of his automobile. It is said that the latter included several capacitors and that a kilowatt level of power was generated. In this case the automobile merely carried the test apparatus for demonstration at a location remote from a built-up area and any

electrical power line interference. No doubt Moray was seeking to follow in Tesla's footsteps by drawing energy from the Earth's electric field, known to be measured in hundreds of volts per metre. It is likely that those capacitors were of Leyden jar type configuration, that is cylindrical in structural form, and that the wire linked to tree tops tapped charge at a kilovolt voltage level. However, the output power claimed could surely not have come from that source. Therefore one must assume that Moray used that treetop voltage input merely to prime the voltage across his capacitor electrodes, whilst incorporating some special feature in the operation of his electrical circuit that gave access to the energy of the quantum underworld. Capacitors having concentric electrodes of cylindrical form will, when charged electrically, have a radial electric field in the space between the electrodes. Several capacitors coupled together could give rise to oscillations of charge as between the capacitors and so lead to a pulsating radial electric field. Yet though demonstrating as possible something that should not be possible, a mysterious inflow of energy able to illuminate several light bulbs, Moray could surely not have understood the true physical process that was feeding energy into his apparatus. Again I see this as relevant to what is stated in Message No. 1.

Stan Meyer demonstrated apparatus that included sets of concentric tubular electrodes enclosed in a cylindrical container filled with water, the electrodes being fed by high voltage (5 KV) pulses. Combustible gas was generated, a mixture of hydrogen and oxygen, the burning of which generated far more heat than could be accounted for by the electrical energy input. Energy was being tapped as if from nowhere unless the source was the ambient medium of space itself. Here there was a pulsating radial electric field and electric charge oscillating between different components in Meyer's apparatus. Meyer did not offer any useful explanation as to the physical process underlying what he could demonstrate but persisted in conveying the message that the invention was wonderful and talking about a multiplicity of applications such as powering automobiles, ships etc. This is the project not mentioned in Keith Tutt's book. As for the Tesla and Moray projects Meyer's research was a U.S. based activity. It did, however, attract the interest of a British Admiral, Admiral Tony Griffin who was concerned with the impact of new technology upon the marine industries. Griffin witnessed Meyer's demonstrations and was interested in its development. Indeed an article on the subject mentioning Admiral Griffin and entitled 'Free Energy for Ever' was published in the January 1991 issue of the U.K. magazine *Wireless World*. The importance of the article was evident from the fact that the Editor of that magazine was the author.

Paul Baumann, a member of a Christian community in a isolated valley high in the Swiss Alps has constructed working free energy devices which have been demonstrated to visitors. The first working prototype was relatively small and included a pair of glass Leyden jars, concentric capacitors. Keith Tutt in his book devotes 30 pages to this subject. The high voltage needed to prime the capacitor operation was generated by a Wimshurst machine driven by the electric power generated. The community has, however, kept design details secret. In spite of such information as is available the underlying physical process governing its operation remains a mystery. Yet I can but feel confident that what I say in my Message No. 1 provides the answer.

Message No. 3: My Message No. 1 has drawn attention to the physical process by which the vast amount of energy needed to create the Sun was extracted from the quantum underworld that permeates all space. My Message No. 2 has drawn attention to the reported efforts of just some of the several energy research pioneers who actually demonstrated apparatus that, contrary to accepted scientific principles, drew energy from a mystery source. My Message No. 3, based on recognising the common physical feature can but be the suggestion that technology for generating our power needs from the hidden underworld of space has to be possible. Accordingly, I will now outline what I see as the basis on which to build the ultimate power generating device that harnesses the physical principles presented in Message No. 1.

Being 78 years of age and no longer having access to university research laboratory facilities, I can but leave it to others to take note and, hopefully, prove me right. If proved right then the world will benefit and the impending energy crisis will be avoided. Hopefully also, the scientific community might then be willing to accept my claim as to how the quantum underworld deploys its energy into proton creation and is active in producing the phenomenon of gravitation. I know of no other theory that has been able to derive theoretically the value 1836.152 of the proton/electron mass ratio. I would like to see that recognised as my contribution to man's knowledge.

Consider a capacitor formed by a pair of concentric cylindrical electrodes, something many of us remember from the school physics laboratory, the Leyden jar. However, the capacitor structure I have in mind is very much larger and has to be operated at a quite high voltage. When that voltage is applied between the electrodes electric charge is displaced in the underlying vacuum medium located between those electrodes. A commensurate amount of electric charge is thereby held in place on those electrodes, a negative polarity charge on one and a positive polarity charge on the other. Given my claim that this is accompanied by 'vacuum spin', aether rotation, which has imported an equal amount of energy owing to a quantum phase-lock as between the charge of the vacuum medium, we have the energy gain we seek to exploit.

The problem, however, is that, with this simple capacitor configuration, the only control parameter available is the reduction of the voltage between the electrodes. This will shed energy within the circuit of the apparatus used, the

outflow of electric charge at the voltage difference merely delivering energy equal to that originally supplied by our voltage source. The added energy imported from space is merely dispersed by the 'vacuum spin' slowing down but expanding beyond the bounds of the capacitor electrodes as it conserves its angular momentum. The energy imported from the quantum underworld of space has no way of enhancing the energy output of the capacitor circuit and so is left to dissipate itself and eventually be reabsorbed by that quantum underworld that pervades all space.

However, now consider a concentric electrode capacitor having a third cylindrical electrode intermediate the inner and outer electrodes. Here we have a control parameter other than the voltage between the outermost and innermost electrodes, because we can wonder about the voltage of the central electrode whilst retaining the other voltage difference at a constant high level. In fact, by keeping the latter voltage difference constant but varying the voltage of the intermediate electrode we can decrease the capacitor energy of one half of the overall capacitor as that of the other half decreases. The imported energy shed by one half of the overall capacitor can then contribute to the action that energises the other half and thereby induce oscillations from which energy can be extracted and deployed as a power source.

One needs two such capacitors having their central electrodes coupled through a load circuit in order to capture the 'free energy' inflow and get it to do useful work rather than being dissipated. An inductance in the coupling circuit can determine the oscillation frequency and, since the energy inflow increases with frequency, this should no doubt be well into the kilocycle region. The figure below is a simple schematic diagram of the electrical apparatus that I have in mind.

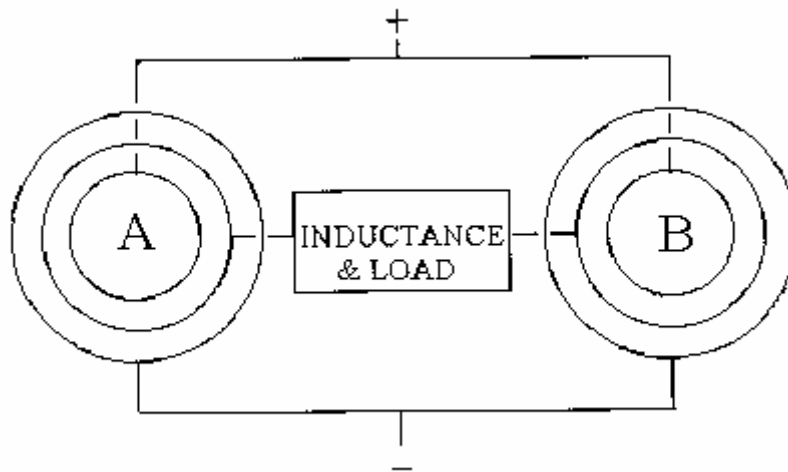

So my Message No. 3 is what I may describe as a 'thought experiment', one that I cannot verify myself, owing to my age and lack of facilities. I therefore can but record my thoughts and hope that others will prove me right and not wrong.

The capacitors depicted in the figure should have their electrodes spaced so that the capacitance C as between their central and outermost electrodes is the same as the capacitance C between their central and innermost electrodes. Suppose that the outermost electrodes are maintained at a voltage of 20,000V relative to the innermost electrodes. This means that the two central electrodes will be at an intermediate voltage which we expect to be 10,000V in the absence of oscillations. However, as with any ever-active electrical system, there will be minor voltage fluctuations affecting the central electrodes. So we may ask what happens if the voltage of the central electrode of capacitor A decreases owing to electric charge being shed by the inner capacitance C but gained by the outer capacitance C . Think about that for a moment. You will see that it implies reciprocal action in the opposite sense by capacitor B, as current flows from A to B via the central inductor coupling. Yet no net current flows from the 20,000V power source.

Now, of course, common sense backed by our scientific training assures us that this system can but keep its equilibrium without those minor voltage fluctuations building up in some way. Yet, if we heed Message No. 1 and keep in mind Message No. 2, there is a question we must ask. If current does flow through that central link between A and B, one half of A and one half of B both shed energy and so release the imported 'vacuum spin' energy, if such is present. This occurs as other halves of A and B have to gain energy and as angular momentum of the imported 'spin energy' spreads into the other sections of the capacitors. The question then is: "Does that imported energy escape, as it does for the two-electrode capacitor configuration, or might it be retained and so augment the action?"

I submit the answer can only be provided by actual experiment. If the energy does escape then there is nothing

further to discuss. However, if some of that energy is captured then we can expect an escalation of oscillations in that inductive link and so can then say that a new source of energy has been discovered. Those oscillations will be a function of the capacitance C and the inductance of the load circuit. Given a high frequency and a high voltage a significant level of power per unit volume of capacitor structure will be produced. If power output at a level commensurate with the claims of Tesla, Moray, Meyer and Baumann results the world's energy future is then assured. A pollution-free energy resource powered by the quantum underworld of space will be at hand wherever we are on body Earth.

Michael Ognyanov's Self-powered Power Pack. A patent application US 3,766,094 (shown in detail in an accompanying document) gives the details of an interesting device. While it is only an application and not a full patent, the information implies strongly that Michael built and tested many of these devices.

While the power output is low, the design is of considerable interest. It is possible that the device works from picking up the output from many radio stations, although it does not have anything which is intended to be an aerial. It would be interesting to test the device, first, with a telescopic aerial added to it, and second, placed in an earthed metal box.

The device is constructed by casting a small block of a mixture of semiconductor materials such as Selenium with, from 4.85% to 5.5% Tellurium, from 3.95% to 4.2% Germanium, from 2.85% to 3.2% Neodymium, and from 2.0% to 2.5% Gallium. The resulting block is shaped with a dome on one face which is contacted by a short, pointed metal probe. When this arrangement is fed briefly with an oscillating signal, typically in the frequency range of 5.8 to 18 Mhz, it becomes self-powered and can supply electric current to external equipment. The construction is as shown here:

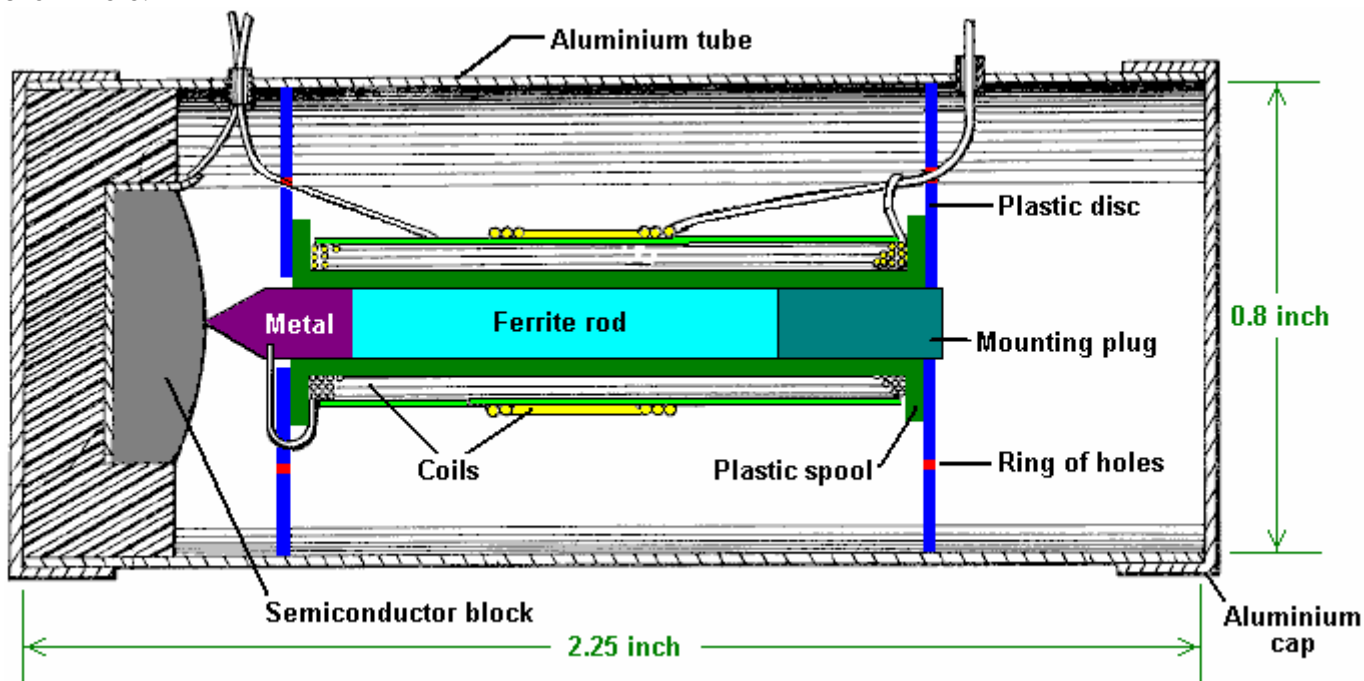

The circuit used with this component is shown as:

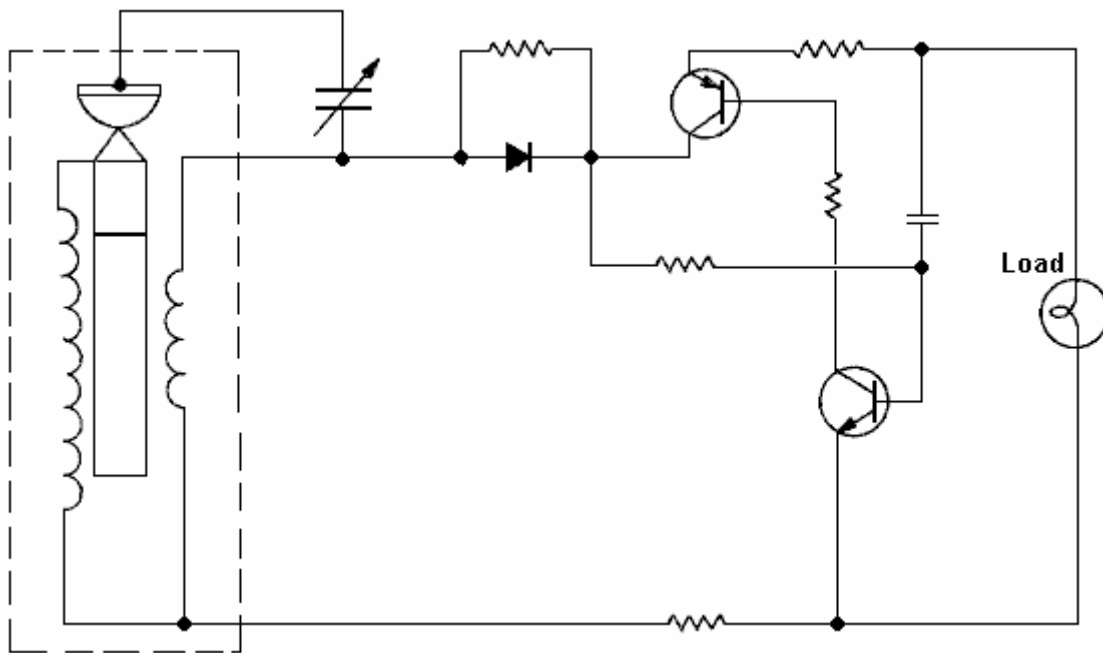

Presumably the output power would be increased by using full-wave rectification of the oscillations rather than the half-wave rectification shown. Michael says that increasing the dimensions of the unit increases the output power. The small unit shown in this example of his, has been shown to be able to provide flashing power for an incandescent lamp of up to 250 mA current requirement. While this is not a large power output, it is interesting that the output is obtained without any apparent input. Michael speculates that the very short connecting wires may act as radio reception aerials. If that is the case, then the output is impressive for such tiny aerials.

Michael Meyer and Yves Mace

There is a French patent application number FR2680613 dated 19th August 1991 entitled "Activeur pour Mutation Isotopique" which provides some very interesting information. The system described is a self-contained solid-state energy converter which abstracts large amounts of energy from an ordinary iron bar.

The inventors describes the technique as an "isotopic mutation effect" as it converts ordinary iron (isotope 56) to isotope 54 iron, releasing large amounts of electrical energy in the process. This excess energy can, they say, be used to drive inverters, motors or generators.

The description of the mechanism which is being used by the device is: "the present invention uses a physical phenomenon to which we draw attention and which we will call 'Isotopic Change'. The physical principle applies to isotope 56 iron which contains 26 protons, 26 electrons and 30 neutrons, giving a total mass of 56.52 Mev, although its actual mass is 55.80 Mev. The difference between the total mass and the actual mass is therefore 0.72 Mev this which corresponds to an energy of cohesion per nucleon of 0.012857 Mev.

So, If one introduces an additional 105 ev of energy to the iron core isotope 56, that core isotope will have a cohesion energy level of 0.012962 Mev per nucleon corresponding to iron isotope 54. The instability created by this contribution of energy will transfer the isotope 56 iron to isotope 54 causing a release of 2 neutrons.

This process generates an excess energy of 20,000 ev since the iron isotope 54 is only 0.70 Mev while isotope 56 has 0.72 Mev. To bring about this iron isotope 56 conversion, we use the principle of Nuclear Magnetic Resonance."

The practical method for doing this is by using three coils of wire and a magnetic-path-closing support frame of iron as shown in this diagram:

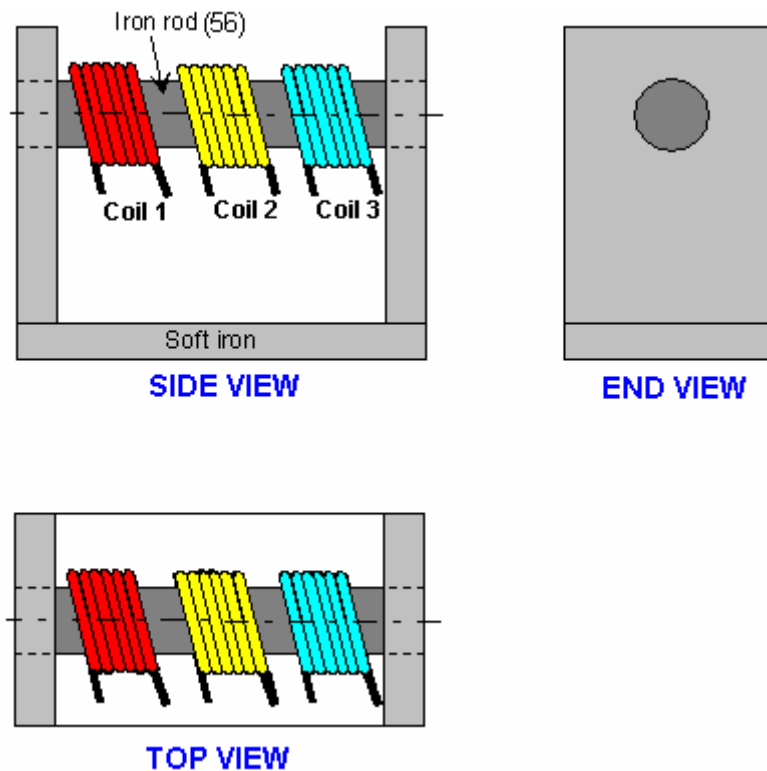

In this arrangement,

Coil 1: Produces 0.5 Tesla when fed with DC, converting the iron bar into an electromagnet

Coil 2: Produces 10 milli-Tesla when fed with a 21 MHz AC sinewave signal

Coil 3: Is the output coil, providing 110, 220 or 380 volts AC at about 400 Hz depending on the number of turns in the coil

This simple and cheap system has the potential for producing substantial energy output for a very long time. The inventors claim that this device can be wired to be self-powered, while still powering external devices. Coil 1 turns the iron rod into an electromagnet with its flux channelled in a loop by the iron yoke. Coil 2 then oscillates that magnetic field in resonance with the isotope 56 iron atoms in the rod, and this produces the isotope conversion and release of excess energy. Coil 3 is wound to produce a convenient output voltage.

Other documents in this series can be downloaded free from <http://www.panaceauniversity.org/> which has additional information in the form of videos, technical papers and patents.